

# **CD Stepper Drive & CC Rack System User Guide**

***For engineering  
assistance in Europe:***  
**Parker Hannifin plc**  
**Digiplan Division**  
21 Balena Close  
Poole, Dorset  
England, BH17 7DX  
Telephone: 0202-699000  
Fax: 0202-695750

***For engineering  
assistance in the U.S.:***  
**Parker Hannifin Corporation**  
**Digiplan Division**  
5500 Business Park Drive  
Rohnert Park, CA 94928  
USA  
Telephone: (800) 358-9070  
Fax: (707) 584-8015

Part No: 1600.148.01 7<sup>th</sup> February 1992

# IMPORTANT INFORMATION FOR USERS

## Installation and Operation of Digiplan Equipment

It is important that Digiplan motion control equipment is installed and operated in such a way that all applicable safety requirements are met. It is your responsibility as a user to ensure that you identify the relevant safety standards and comply with them; failure to do so may result in damage to equipment and personal injury. In particular, you should study the contents of this user guide carefully before installing or operating the equipment.

Under no circumstances will the suppliers of the equipment be liable for any incidental, consequential or special damages of any kind whatsoever, including but not limited to lost profits arising from or in any way connected with the use of the equipment or this user guide.



### **SAFETY WARNING**

High-performance motion control equipment is capable of producing rapid movement and very high forces. Unexpected motion may occur especially during the development of controller programs. **KEEP WELL CLEAR** of any machinery driven by stepper or servo motors. Never touch it while it is in operation.

High voltages exist within enclosed units, on rack system backplanes (motherboards) and on transformer terminals. Keep clear of these areas when power is applied to the equipment.

The information in this user guide, including any apparatus, methods, techniques, and concepts described herein, are the proprietary property of Parker Digiplan or its licensors, and may not be copied, disclosed, or used for any purpose not expressly authorised by the owner thereof.

Since Digiplan constantly strives to improve all of its products, we reserve the right to modify equipment and user guides without prior notice. No part of this user guide may be reproduced in any form without the prior consent of Digiplan.

**© Digiplan Division of Parker Hannifin plc, 1991  
– All Rights Reserved –**

---

## Table of Contents

<b>List Of Figures</b> .....	iii
<b>List Of Tables</b> .....	iv
How to Use This Manual .....	v
Assumptions .....	v
Contents of This Manual.....	v
Installation Process Overview.....	v
Installation Recommendations.....	vi
Conventions.....	vi
Highlighted Text.....	vii
Warnings (Personal Injury) & Cautions (System Damage).....	vii
Related Publications.....	vii
<b>Chapter 1. INTRODUCTION</b> .....	1
Chapter Objective .....	1
Product Description .....	1
CD-Series Drives .....	1
CC Series Rack .....	2
Product Features .....	2
CD Series Drives .....	2
Theory of Operation.....	3
<b>Chapter 2. GETTING STARTED</b> .....	5
Chapter Objectives .....	5
What You Should Have .....	5
Ship Kit Table .....	5
Basic System Configuration (Stand-alone Drive) .....	6
Edge Connections .....	6
Motor Current Selection.....	7
Resolution Control .....	7
Basic System Configuration (Rack-mount Drive) .....	8
Factory Settings.....	8
Motor Connections.....	8
Indexer Connections.....	12
Transformer Connections .....	12
Powering Up the CD Drive.....	14
Functional Test .....	14
<b>Chapter 3. INSTALLATION</b> .....	15
Chapter Objectives .....	15
Complete System Configuration.....	15
Setting Drive Functions (CD25/25M and 35/35M only) .....	15
Setting Drive Functions (CD20, CD30 and CD40 drives only).....	23
Environmental Considerations.....	26
Enclosure Considerations .....	26
Transformer Mounting .....	26
System Connections.....	26
Wiring Guidelines.....	27
Transformer Connections .....	27
Indexer Connections.....	27
Auxiliary Indexer Connections .....	27
<b>Chapter 4. HARDWARE REFERENCE</b> .....	31

ii CD STEPPER DRIVE & CC RACK SYSTEM USER GUIDE

---

Chapter Objectives .....	31
Environmental Specifications .....	31
System Specifications.....	32
Power Supply Specifications.....	33
System Pinouts and Connectors.....	33
I/O Specifications.....	35
I/O Descriptions .....	35
I/O Wiring Diagrams .....	36
Factory Default Settings .....	37
Transformer Wiring.....	38
CC Rack .....	40
Transformers.....	41
<b>Chapter 5. MAINTENANCE &amp; TROUBLESHOOTING .....</b>	<b>43</b>
Chapter Objectives .....	43
Maintenance .....	43
Spare Parts Table.....	43
Motor Maintenance.....	43
Drive Maintenance.....	43
Troubleshooting.....	44
Motor Fails to Move .....	44
Motor Stalls.....	45
Motor Fails to Run at High Speeds.....	46
Motor is Jerky or Weak.....	46
Motor Overheats .....	46
Reducing Electrical Noise.....	46
Returning the System.....	46
<b>Index.....</b>	<b>49</b>

---

## List Of Figures

Figure 1-1.	Typical CD Drive System Functional Block Diagram.....	3
Figure 2-1.	Edge Connections (Stand-alone Drive) .....	6
Figure 2-2.	Motor Connections.....	9
Figure 2-3.	Indexer Connections.....	12
Figure 2-4.	Transformer Connections for 120V AC Input.....	13
Figure 2-5.	Transformer Connections for 240V AC Input.....	13
Figure 3-1.	CD Drive Motherboard DIP Switch and Jumper LK1 Location .....	16
Figure 3-2.	Normal Current Profile (Half-step Mode) .....	18
Figure 3-3.	Current Profile with Square-off.....	18
Figure 3-4.	Locations of Motherboard Resistors R8 and R2.....	20
Figure 3-5.	MS20 DIP Switch Location & Default Setting .....	21
Figure 3-6.	Mini-stepping Current Profiles .....	21
Figure 3-7.	Location of Jumper LK2 on the MS20 Mini-stepping Card .....	22
Figure 3-8.	Location of CD20/30/40 Drive Jumpers and Resistor R59 .....	25
Figure 3-9.	PL1 Auxiliary Indexer Connector .....	28
Figure 3-10.	Fault Output Example .....	28
Figure 4-1.	CD Drive Motherboard Inputs and Outputs .....	34
Figure 4-2.	PM1200B Power Supply Inputs .....	34
Figure 4-3.	Typical CD Drive Input Circuits.....	37
Figure 4-4.	Typical CD Drive Output Circuits.....	37
Figure 4-5.	Transformer Wiring .....	39
Figure 4-6.	CC Rack Dimensions.....	40
Figure 4-7.	Transformer Model TO92 Dimensions.....	41
Figure 4-8.	Transformer Model TO73 Dimensions.....	42

## List Of Tables

Table 1-1.	CC Series Rack Configurations .....	2
Table 2-1.	CC Rack System Ship Kits .....	5
Table 2-2.	Motor Current Resistor Values for Stand-alone Drives.....	7
Table 2-3.	Resolutions for CD25, 25M, 35, and 35M Drives.....	7
Table 2-4.	Motor Connection Data - Windings in Series .....	10
Table 2-5.	Motor Connection Data - Windings in Parallel .....	11
Table 2-6.	Indexer Connector Pinouts .....	12
Table 3-1.	CD Drive Motherboard DIP Switch Functions.....	16
Table 3-2.	Motor Current DIP Switch Settings (Full Range) .....	17
Table 3-3.	Square-Off DIP Switch Settings.....	19
Table 3-4.	Mode Selections using DIP Switches 7 and 8 .....	19
Table 3-5.	MS20 DIP Switch Examples .....	21
Table 3-6.	Motor Current R59 Values .....	25
Table 4-1.	CD Drive Specifications .....	33
Table 4-2.	PM1200B Power Supply Specifications.....	33
Table 4-3.	Indexer Input Specifications.....	35
Table 4-4.	Auxiliary Drive I/O Specifications .....	35
Table 4-5.	CD Drive Factory Default Settings .....	38
Table 4-6.	Default and Optional Transformer Settings.....	39
Table 5-1.	Recommended Spare Parts for the CD Drive Rack-mount System .....	43

---

**How to Use  
This Manual**

This manual is designed to help you install, develop, and maintain your system. Each chapter begins with a list of specific objectives that should be met after you have read the chapter. This section is intended to help you find and use the information in this manual.

---

**Assumptions**

This user guide assumes that you have the skills or fundamental understanding of the following:

- Basic electronics concepts (voltage, switches, current, resistors, etc.)
- Basic motion control concepts (torque, velocity, distance, etc.)

With this basic level of understanding, you will be able to effectively use this manual to install, develop, and maintain your system.

---

**Contents of This  
Manual**

This user guide contains the following information:

**Chapter 1:  
Introduction**

This chapter provides a description of the product and a brief account of its specific features.

**Chapter 2: Getting  
Started**

This chapter contains a detailed list of items you should have received with your CD Drive system shipment. It will help you become familiar with the system and ensure that each component functions properly. In this chapter, you will perform a preliminary configuration of the system.

**Chapter 3:  
Installation**

This chapter provides instructions for you to properly mount the system and make all electrical and non-electrical connections. Upon completion of this chapter, your system should be completely configured, installed, and ready to perform basic operations.

**Chapter 4:  
Hardware  
Reference**

This chapter contains information on system specifications (dimensions and performance). This chapter may be used as a quick-reference tool for proper switch settings and I/O connections.

**Chapter 5:  
Maintenance &  
Trouble-shooting**

This chapter describes recommended system maintenance and troubleshooting procedures. It also provides methods for isolating and resolving hardware and software problems.

---

**Installation  
Process  
Overview**

To ensure trouble-free operation, you should pay special attention to the following:

- The environment in which the system will operate
- The system layout and mounting
- The wiring and grounding practices used

These recommendations are intended to help you easily and safely integrate the CD Drive system into your equipment.

---

**Installation  
Recommendations**

Before you attempt to install this product, you should complete the following steps:

- Step 1** Review this entire manual. Become familiar with the manual's contents so that you can quickly find the information you need.
- Step 2** Develop a basic understanding of all system components, their functions, and interrelationships.
- Step 3** Complete the basic system configuration and wiring instructions provided in Chapter 2, Getting Started. Note that this is a preliminary configuration, not a permanent installation, usually performed in a bench-top environment.
- Step 4** Perform as many basic moves and functions as you can with the preliminary configuration. You can perform this task only if you have reviewed the entire manual. You should try to simulate the task(s) that you expect to perform when you permanently install your system. *However, do not attach a load at this time.* This will give you a realistic preview of what to expect from the complete configuration.
- Step 5** After you have tested all of the system's functions and used or become familiar with the features, carefully read Chapter 3, Installation.
- Step 6** After you have read Chapter 3 and clearly understand what must be done to properly install the system, you should begin the installation process. **Proceed in a linear manner**; do not deviate from the sequence or installation methods provided.
- Step 7** Before you begin to customize your system, check all of the system functions and features to ensure that you have completed the installation process correctly.

The successful completion of these steps will prevent subsequent performance problems and allow you to isolate and resolve any potential system difficulties before they affect your system's operation.

---

**Conventions**

To help you understand and use this user guide effectively, the conventions used throughout this manual are explained in this section.



---

**Highlighted Text**

Several methods are used to highlight text. Explanations of special text and the way it is highlighted are presented below.

---

**Warnings (Personal Injury) & Cautions (System Damage)**

Warning and caution notes alert you to possible dangers that may occur if you do not follow instructions correctly. Situations that may cause bodily injury are presented as warnings. Situations that may cause system damage are presented as cautions. Refer to the examples shown below.

**WARNING**

**Do not touch the motor immediately after it has been in use for an extended period of time. The unit will be hot.**

**CAUTION**

**System damage will occur if you power up the system improperly.**

Italics are used to highlight other important material. Refer to the example below.

Example: By doubling the resistor value, you can double the square-off speed. *Do not use a resistor with a value lower than 3.3k $\Omega$ .*

---

**Related Publications**

The following publications may be helpful resources:

- *Digiplan Programmable Motion Control Catalogue*
- Schram, Peter (editor). *The National Electric Code Handbook (Third Edition)*. Quincy, MA: National Fire Protection Association

---

## Chapter 1. INTRODUCTION

---

### Chapter Objective

The information in this chapter will enable you to understand the product's basic functions and features.

---

### Product Description

#### CD-Series Drives

CD drives are high-performance, bipolar, chopper-regulated stepper drives designed to operate with a wide range of rotary stepper motors. The PM1200B power supply provides power to the CD drives. When mounted in a CC series rack, CD series drives can be controlled from a standard Digiplan or Compumotor indexer.

CD drives are available in multiple configurations in CC series rack assemblies, or separately as stand-alone units. The CD series comprises the following drives:

- CD20
- CD25
- CD25M
- CD30
- CD35
- CD35M
- CD40

CD20, CD25, CD30, CD35 and CD40 drives operate rotary stepper motors at resolutions of either 200 steps/rev (full-step) or 400 steps/rev (half-step). The CD25M and CD35M drives are fitted with the MS20 mini-stepping card that increases step resolution by a factor of 5 or 10, producing a higher resolution of 1,000 or 2,000 steps/rev with a standard 200-step motor.

#### CC Series Rack

The CC series pre-wired rack assembly can house up to four CD drives and one PM1200B power supply. Each rack system is based on a 19"-long, 3U high rack with individual motherboards mounted on the back. The drives and power supply are mounted into the rack and plugged directly into their corresponding motherboards. This design provides a compact package, maximum flexibility, and simple solder-free screw terminal connectors. All racks fit into standard 19" rack-mount system cabinets. Table 1-1 identifies the CC racks and the number of drives and power supplies each type of rack is capable of accommodating. The CC10 and CC20 racks can also house the MC20 indexer module.

Model No.	CD Drives	Power Supplies
CC10	1	1
CC20	2	1
CC30	3	1
CC40	4	1

**Table 1-1. CC Series Rack Configurations**

---

### Product Features

#### CD Series Drives

Features of the CD drives are as follows:

- CD drives control rotary stepper motors with frame sizes of 23, 34, and 42 .
- A recirculating chopper regulator improves efficiency and reduces motor heat.
- Dual-mode chopping permits the drive to achieve precise motor current control at all times, resulting in increased torque output and smoother operation.
- The MS20 mini-stepping card allows the CD25M and CD35M to increase the step resolution by a factor of 5 or 10, producing resolutions of 1,000 or 2,000 steps per revolution.
- The DIP switch selectable motor current allows you to configure the drive for a wide range of motors (CD25, 35, 25M, and 35M only).
- Automatic current standby reduces current at standstill, which minimizes motor and drive heating.
- Torque boost enables you to increase the current by 30% at strategic times, such as during acceleration.
- The drive operates at motor supply voltages up to 85V for high-speed performance.
- Motor short-circuit protection is assured across phase, between phases and to ground.
- A thermal sensor monitors the heatsink temperature.
- LED indicators assist in set-up and fault diagnostics.
- An anti-resonance circuit detects the onset of system resonance and modifies the current profile (CD25, 35, 25M, and 35M only).
- An automatic square-off circuit provides improved mid-range torque (CD25, 35, 25M, and 35M only).

---

### Theory of Operation

A typical stepper drive installation is shown in Figure 1-1.

The external indexer receives ASCII commands (from a computer or PLC) or binary signals (from remote switches, PLC, or thumbwheel

interface). The indexer then converts these commands or signals to step pulses and sends them to the CD drive via the motherboard (if installed in a rack). These step pulses, are coupled with a direction signal to control motor velocity, acceleration, direction, and position. The CD drive converts the step pulses to varied motor currents to control the stepper motor's rotation and angular position. The motor converts electrical pulses into discrete mechanical motion (shaft rotation). An optional encoder mounted either on the motor or on the load provides positional feedback (encoder pulses) to the indexer.

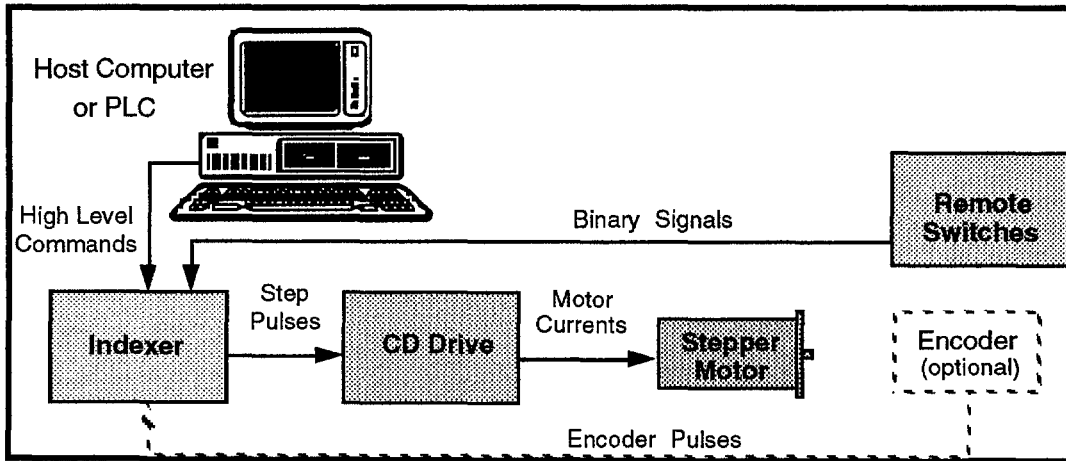

**Figure 1-1. Typical CD Drive System Functional Block Diagram**

For a detailed description of stepper motor construction and operation, refer to the *Digiplan Programmable Motion Control Catalogue*.



## Chapter 2. GETTING STARTED

### Chapter Objectives

The information in this chapter will enable you to do the following:

- Verify that each component of your system has been delivered safely
- Become familiar with system components and their interrelationships
- Establish the basic system configuration
- Ensure that each component functions properly

### What You Should Have

The CD drive system is normally shipped with all components pre-wired and installed in the appropriate CC rack system.

Upon receipt, you should inspect your system shipment for obvious damage to its shipping container. Report any such damage to the shipping company as soon as possible. Carefully unpack and inspect your CD drive system shipment. The items listed in Table 2-1 should be present and in good condition.

### Ship Kit Table

Table 2-1 identifies ship kits corresponding with the four different CC racks: CC10, CC20, CC30, and CC40.

Description	Part Number	CC10	CC20	CC30	CC40
Choice of Drives: CD20 CD25 CD25M CD30 CD35 CD35M CD40	CD20 CD25 CD25M CD30 CD35 CD35M CD40	1 (Total)	2 (Total)	3 (Total)	4 (Total)
Power Supply	PM1200B	1	1	1	1
Choice of Transformers: Model TO73 Model TO92	TO73 TO92	----- 1	----- 1	1 (Either Model)	1 -----
Choice of Front Panels: for CD20 for CD30 for CD25, & 25M for CD35 & 35M CD40	FP1 FP2 FP10 FP11 FP4	1 (Total)	2 (Total)	3 (Total)	4 (Total)
Blank Front Panel	FP5	3	2	1	-----
User Guide	1600.148.XX	1	1	1	1
Motors	*	1	2	3	4

\* If the motors are supplied by Digiplan, please refer to the separate motor manual.

**Table 2-1. CC Rack System Ship Kits**

### Basic System Configuration (Stand-alone)

If you are using the CD drive without a CC rack, use the information in this section to configure the drive and perform edge connections. If you are using a rack, skip this section and proceed to Basic

**Drive)** System Configuration (Rack-mount Drive).

**Edge Connections**

Figure 2-1 illustrates the pinouts on the edge connector located on the back of the drive. When you purchase a *drive only* module, a mating solder-type connector is provided to make user connections. When making your connections, be sure to consider the following points:

- The motor supply to the drive should be protected by a *fast-blow* fuse with a reverse bypass diode. This ensures that if the fuse fails there is a return path for regenerated current back to the supply capacitor (see Figure 2-1). Use a 5A fuse for CD20, 25, and 25M drives. Use a 10A fuse for CD30, 35, and 35M drives. Use a 15A fuse for the CD40.

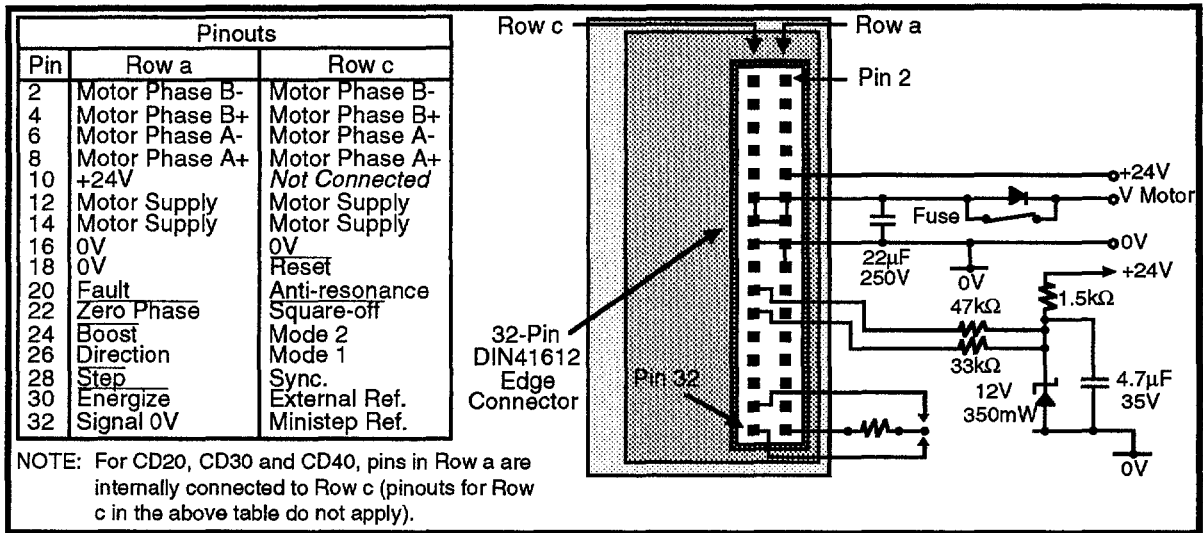

**Figure 2-1. Edge Connections (Stand-alone Drive)**

- A local decoupling capacitor (22µF, 250V) must be installed across the motor supply as close as possible to the drive edge connector (see Figure 2-1).
- For CD25, 25M, 35, and 35M drives, the anti-resonance and square-off inputs (pins 20c and 22c respectively) need 47kΩ and 33kΩ (respectively) pull-up resistors to +12V. These components determine the cut-off speed of the corresponding function. They are external to the drive for ease of modification. Since the required pull-up voltage is not available on the edge connector, it must be generated from +24V by a zener diode as illustrated in Figure 2-1.
- You can set the drive output current to the motor using a single resistor. Refer to Table 2-2 for current selections. *NOTE: This resistor is connected between pin 32a and pin 30c on CD25 and 35 drives, or between pin 32a and pin 32c on CD25M and 35M drives (see Figure 2-1).*

**Motor Current  
Selection**

Table 2-2 provides resistor values for various motor currents.

**NOTE: These resistor values do not apply to CD20 and 30 Drives.** The motor current for CD20 and 30 Drives can be changed only by changing the value of resistor R59 in the drive translator card (see Chapter 3).



Resistor Value	Motor Current	
	CD25M	CD35M
Open-circuit	3A	6A
4K7	2.75A	5.5A
3K3	2.5A	5A
2K4	2.25A	4.5A
1K8	2A	4A
1K5	1.75A	3.5A
1K	1.5A	3A

Table 2-2. Motor Current Resistor Values for Stand-alone Drives

**Resolution Control**

Table 2-3 provides the optional drive resolutions selected by the mode inputs (pins 24c and 26c). **NOTE: This applies only to CD25, 25M, 35, and 35M drives.**

Mode 1	Mode 2	Resolution
High	Low	200 steps/rev
High	High	400 steps/rev
Low	High	1,000 steps/rev*
Low	Low	2,000 steps/rev*

\* Resolution for CD 25M and CD35M Drives only

NOTE: High = +12V (open), Low = Signal 0V (grounded)

**Basic System Configuration (Rack-mount Drive)****Table 2-3. Resolutions for CD25, 25M, 35, and 35M Drives**

CD drives are protected against short-circuit and over-temperature. Nevertheless, it is not recommend that you test these features or operate your system in a way that will induce short-circuit or over-temperature situations.

The CD drive system is normally shipped with the drive(s) and PM1200B power supply pre-installed in the appropriate CC rack.

**CAUTION**

**Ensure the AC power is disconnected before attempting to perform any system connections. Never disconnect the motor with power on; this will damage the drive and the motor connector contacts. Follow the steps described below to complete the basic configuration of your system.**

**Factory Settings**

Rack-mount CD drive functions are factory-set to provide optimum system performance and safe operation. You do not need to alter these settings to accommodate the preliminary system operation and testing discussed in this chapter. Normally, these factory settings, with the exception of motor current, will satisfy the complete system operating requirements. Chapter 3, Installation, discusses optional drive settings you can use for your particular application.

The basic drive operating conditions are factory set as follows:

- Drive current is set at maximum:
  - CD20/25/25M     3A
  - CD30/35/35M     6A
  - CD40             9A
  
- Drive resolution is set at maximum:
  - CD20, CD25, CD30, and CD35     400 steps/rev
  - CD25M and CD35M                 2,000 steps/rev

#### **Motor Connections**

If you purchased a Digiplan stepper motor with the CD drive system, it will be pre-wired and ready to connect to the motherboard. Refer to Figure 2-2 for motor connections.

If you are using a motor from another supplier, refer to Tables 2-4 and 2-5 to determine which motor wires correspond to Phase A and Phase B. After you determine the motor's wiring configuration, connect the motor leads to the five-pin, two-part screw terminal connector (TB1) on the CD drive motherboard.

**CAUTION**

Be sure to properly connect the motor to the motherboard. Incorrect connections can cause damage to the drive and the motor.

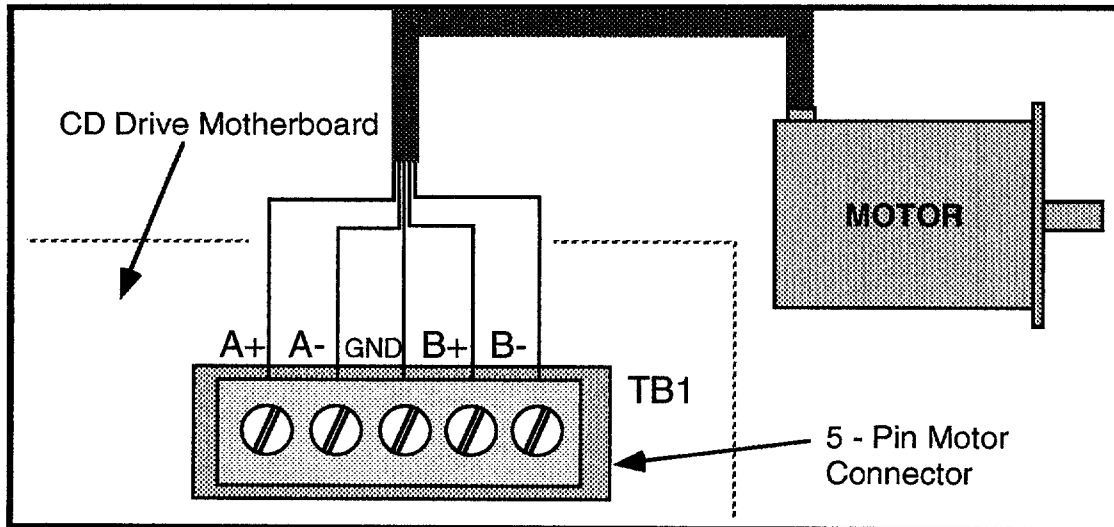

**Figure 2-2. Motor Connections**

N.C. - no connection.						
MAKE	TYPE	A+	A-	B-	B+	NOTES
Evershed & Vignoles	6-lead	Red	Green	Blue	Yellow	Brown & Black N.C.
	8-lead	Red	Green	Blue	Yellow	Link Grey & Pink, link White & Violet
	T.box	1	3	4	2	Link 5 & 6, link 7 & 8
Sigma	6-lead	Black	Orange	Red	Yellow	White/Blk/Org, White/Red/Yel N.C.
	8-lead	Black	Orange	Red	Yellow	Link Wh/Blk & Wh/Org Link Wh/Red & Wh/Yel
	T.box	1	3	2	4	Link 5 & 6, link 7 & 8
Astrosyn, Rapidsyn, Slo-syn	6-lead	Red	Red/Wh	Grn	Grn/Wh	White & Black N.C.
	T.box (x6)	1	3	4	5	2 & 6 N.C.
Slo-syn	8-lead	Red	Red/Wh	Grn	Grn/Wh	Link Black & White, link Org & Blk/Wh
	T.box (x8)	1	3	5	4	Link 2 & 6, link 7 & 8
Stebon	8-lead	Red	Yel	Pink	Blk	Link Blue & violet, link White & Grey
	T.box	1	2	3	4	Link 5 & 6, link 7 & 8
G.E.C.	T.box	1	2	3	4	Link 5 & 6, link 7 & 8
M.A.E.	6-lead	Grn/Wh	Grn	Red	Red/Wh	White & Black N.C.
	8-lead	Black	Orange	Red	Yellow	Link Wh/Blk & Wh/Org, Link Wh/Red & Wh/Yel
	T.box	6	5	8	7	Link 1 & 3, link 2 & 4
Zebotronics	T.box	1	4	5	8	Link 2 & 3, link 6 & 7
Oriental	6-lead	Black	Green	Red	Blue	Yellow & White N.C.
Sonceboz	8-lead	Green	Grn/Wh	Red	Red/Wh	Link Org & Blk/Wh, link Black & White
Japan Servo	6-lead	Red	Blue	Green	Yellow	2 x White N.C.
Escap	8-lead	Brown	Org/Wh	Red	Yel/Wh	Link Brn/Wh & Org, Link Red/Wh & Yellow.
Bodine	8-lead	Brown	Orange	Yellow	Red	Link Wh/Brn & Wh/Org, link Wh/Yel & Wh/Red.
	T.box	1	3	4	2	Link 5 & 7, link 6 & 8
Digiplan/Compumotor RM Motor	8-lead	Black	Orange	Red	Yellow	Link Wh/Blk & Wh/Org. Link Wh/Red & Wh/Yel
Digiplan/Compumotor QM Motor	8-lead	Red	Black	White	Green	Link Yel & Blue Link Org & Brown

Table 2-4. Motor Connection Data - Windings in Series

## 12 CD STEPPER DRIVE & CC RACK SYSTEM USER GUIDE

For 6-lead motors, connections shown are for one half-winding.

N.C. - no connection.

MAKE	TYPE	A+	A-	B-	B+	NOTES
Evershed & Vignoles	6-lead	Red	Brown	Blue	Black	Grn & Yellow N.C.
	8-lead	Rd & Pink	Grn & Grey	Blue & Violet	Yel & White	
	T.box	1 & 6	3 & 5	4 & 8	2 & 7	
Sigma	6-lead	Black	Wh/Blk/Orange	Red	Wh/Red/Yellow	Or & Yellow N.C.
	8-lead	Black & Wh/Or	Or & Wh/Blk	Red/Wh/Yel	Yel & Wh/Red	
	T.box	1 & 5	3 & 6	2 & 7	4 & 8	
Astrosyn, Rapidsyn, Slo-syn	6-lead	Red	Black	Green	White	Red/Wh & Grn/Wh N.C.
	T.box(x6)	1	6	4	2	3 & 5 N.C.
Slo-syn	8-lead	Red & White	Blk & Red/Wh	Grn & Blk/Wh	Org & Grn/Wh	
	T.box(x8)	1 & 2	3 & 6	4 & 7	5 & 8	
Stebon	8-lead	Rd & Blue	Yel & Violet	Wh & Pink	Black & Grey	
	T.box	1 & 6	2 & 5	3 & 8	4 & 7	
G.E.C.	T.box	1 & 6	2 & 5	3 & 8	4 & 7	
M.A.E.	6-lead	Grn/Wh	White	Red	Black	Grn & Red N.C.
	8-lead	Black & Wh/Or	Or & Wh/Blk	Red & Wh/Yel	Yel & Wh/Red	
	T.box	3 & 6	1 & 5	4 & 8	2 & 7	
Zebotronics	T.box	1 & 2	3 & 4	5 & 6	7 & 8	
Oriental	6-lead	Black	Yellow	Red	White	Grn & Blue N.C.
Sonceboz	8-lead	Grn & Blk/Wh	Or & Grn/Wh	Red & White	Blk & Red/Wh	
Japan Servo	6-lead	Red	White*	Green	White*	
Escap	8-lead	Brn & Orange	Brn/Wh & Org/Wh	Red & Yellow	Red/Wh & Yel/Wh	
Bodine	8-lead	Brn & Wh/Or	Wh/Brn & Orange	Yel & Wh/Red	Wh/Yel & Red	
	T.box	1 & 7	3 & 5	4 & 6	2 & 8	
Digiplan/Compumotor RM Motor	8-lead	Black & Wh/Or	Orange & Wh/Black	Red & Wh/Yellow	Yellow & Wh/Red	
Digiplan/Compumotor QM Motor	8-lead	Red & Blue	Blk & Yellow	Wh & Brn	Green & Org.	

\* Use correct White for each phase.

**Table 2-5. Motor Connection Data - Windings in Parallel**

**Indexer Connections**

Refer to Figure 2-3 for proper connections to the Indexer connector (SKT1) on the CD drive motherboard.

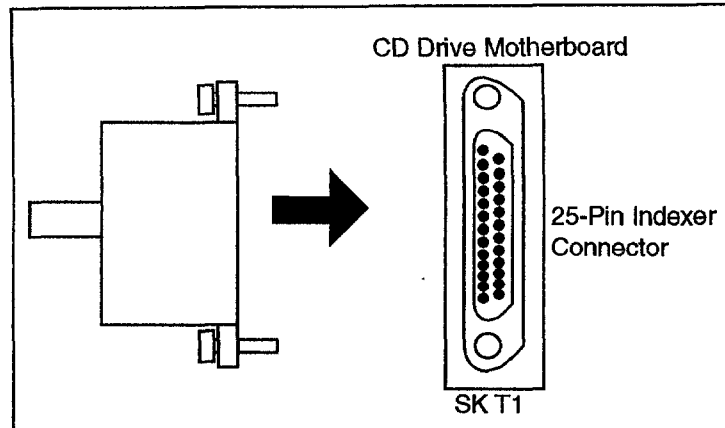

**Figure 2-3. Indexer Connections**

Table 2-6 provides the pinouts for the 25-pin connector on the CD drive motherboard.

Pin	Function
1	STEP +
14	STEP -
2	DIRECTION +
15	DIRECTION -
16	SHUTDOWN +
17	SHUTDOWN -
9	FAULT +
21	FAULT -

NOTE: All other pins are not used

**Table 2-6. Indexer Connector Pinouts**

### Transformer Connections

The last step in the basic configuration is to connect the transformer to the PM1200 motherboard. Transformers supplied in the USA are pre-wired ready to connect to the PM1200 motherboard and are set to operate with 120V AC input.

As illustrated in Figure 2-4, the transformer leads are connected to the five barrier strip terminals (connector TB1) on the back of the PM1200 motherboard.

**WARNING**

**Do not connect the transformer to the PM1200 motherboard while power is applied to the transformer. Do not touch the wiring studs on the transformer after it is plugged into an AC outlet. This can cause serious personal injury.**

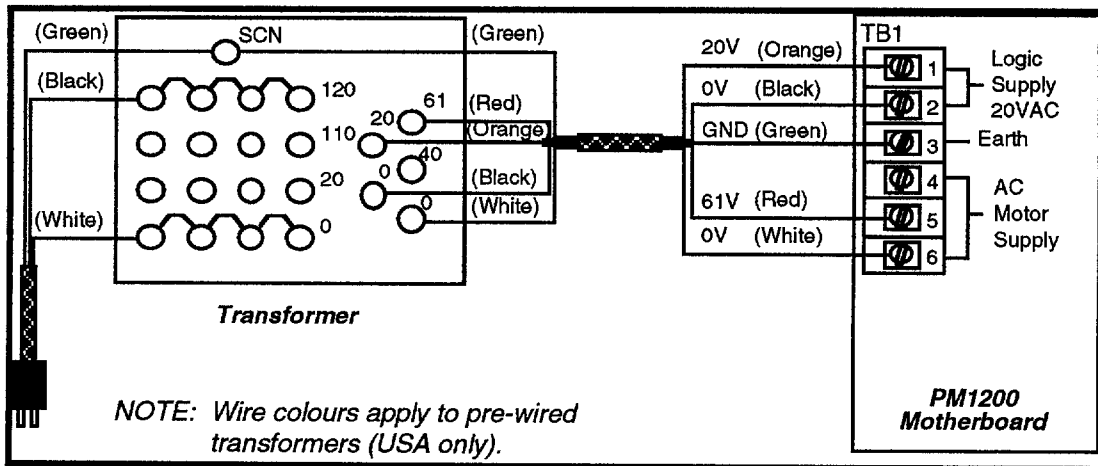

**Figure 2-4. Transformer Connections for 120V AC Input**

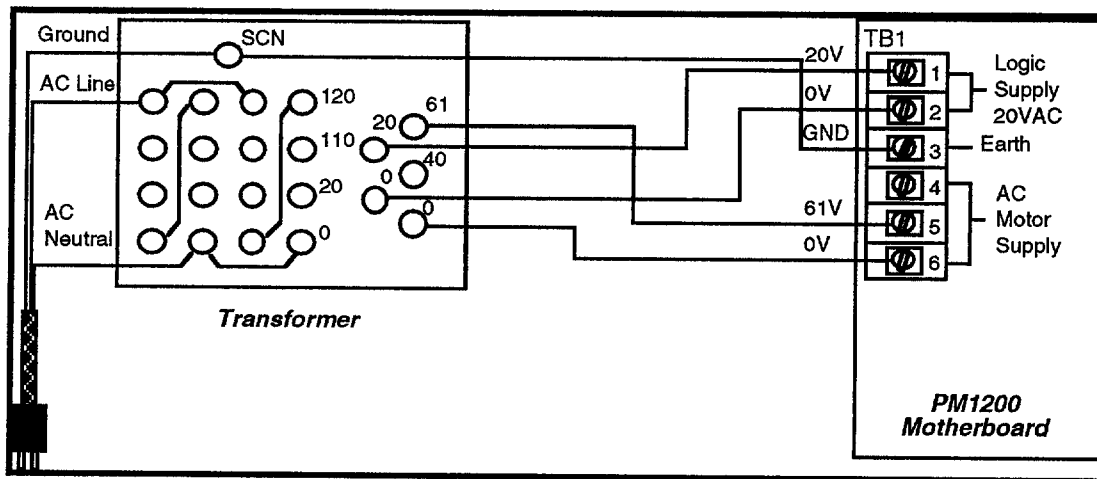

**Figure 2-5. Transformer Connections for 240V AC Input**

**Powering Up the CD Drive**

Before you power-up the CD drive, you should verify that the power and motor cables are properly connected. If everything is OK, the drive will be enabled (evident by *holding torque* on the motor) when you apply power.

If the drive is functioning properly, the green ZERO PHASE LED will be on and the red LEDs will be off. If the power supply is functioning properly, both power supply LEDs will be on.

If there is a short-circuit, over-temperature, or undervoltage condition, the corresponding red LED will be illuminated. If one of the red drive LEDs illuminate, or if the motor does not have holding torque, remove power to the system and refer to Chapter 5, Maintenance and Troubleshooting.

---

**Functional Test**

Use the following procedures to test the functionality of the CD drive system and to verify proper system connections.

**STEP 1**

Set up the indexer to run in accordance with the installation procedures outlined in the indexer manual. Make sure the indexer resolution (steps/rev) matches the drive resolution setting.

**STEP 2**

Apply power to the drive and set the indexer to perform a move with the following parameters:

- Step Pulse Width = Minimum of 5 $\mu$ s
- Velocity = 4 revolutions per second (rps)
- Acceleration = 5 rps<sup>2</sup>
- Distance = 4,000 steps

Executing this move should cause the motor to make a 4,000-step move. If you are using a CD20, CD25, CD30, CD35 or CD40 drive, the motor should turn 10 revolutions. If you are using a CD25M or CD35M drive, the motor should turn 2 revolutions.

If the motor does not move, refer to Chapter 5, Maintenance and Troubleshooting.



---

## Chapter 3. INSTALLATION

---

### Chapter Objectives

The information in this chapter will enable you to do the following:

- Mount all system components properly
- Connect all electrical system inputs and outputs properly
- Ensure that the complete system is installed properly
- Perform basic system operations

*NOTE: You should complete all steps in Chapter 2, Getting Started, before proceeding with the steps in this chapter.*

---

### Complete System Configuration

In this section, you will go through complete set-up procedures for setting drive functions.

**WARNING**

**NEVER adjust terminal or DIP switch settings when the power is on.**

---

### Setting Drive Functions (CD25/25M & CD35/35M only)

This section discusses setting drive functions for CD25, CD25M, CD35, and CD35M drives only. Drive settings for the CD20, CD30 and CD40 are discussed later in this chapter.

Drive functions are set by means of DIP switches and jumper links. These are factory-set to provide optimum operation in most applications. You may, however, need to alter these settings to satisfy the particular operating requirements for your application.

**WARNING**

**To change DIP switch and jumper link settings you must remove the drive from the rack. Do not remove the drive modules while power is applied to the rack.**

---

Some drive functions can also be set by changing resistors on the back of the CD drive motherboard.

### Selecting Drive Resolution

Incorporated on the inside of the CD drive motherboard is a two-position Jumper (LK1) (refer to Figure 3-1). For CD25 and CD35 drives, LK1 must be set to position **A** for operating in the full-step (200 steps/rev) or half-step (400 steps/rev) modes. For CD25M and CD35M drives, LK1 is factory-set to position **B** for operating in the mini-stepping mode (1,000 or 2,000 steps/rev).

**Motherboard DIP Switch Settings**

A 10-position DIP switch is located on the inside of the drive motherboard (see Figure 3-1). This DIP switch is used for setting drive operating conditions. Refer to Table 3-1 for DIP switch functions.

To access the DIP switch, remove the four screws securing the drive and pull the drive from the rack. *NOTE: When re-installing the drive, make sure the drive follows the guides in the rack. This will ensure proper connection to the motherboard.*

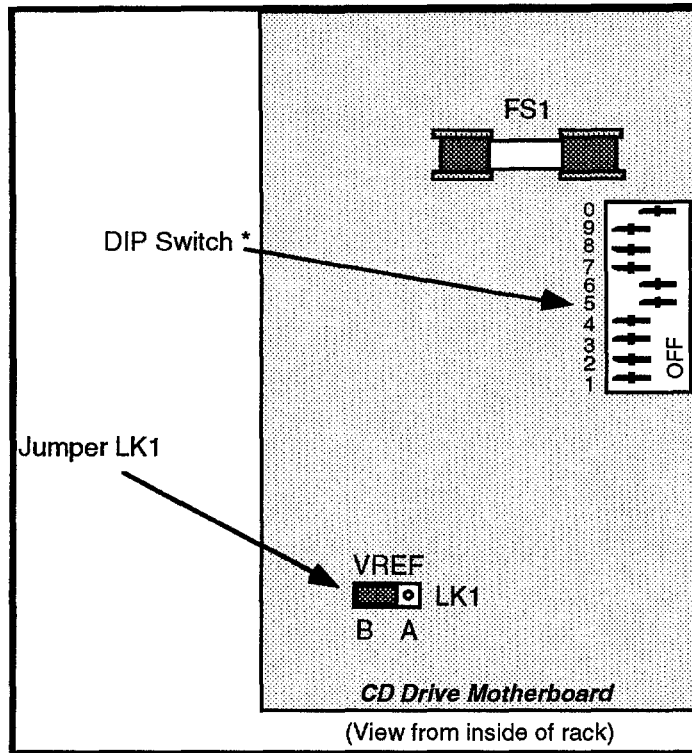

**Figure 3-1. CD Drive Motherboard DIP Switch and Jumper LK1 Location**

DIP Switch Number	DIP Switch Function
1 - 4	Current programming
5	Square-off
6	Anti-resonance
7 & 8	Mode (resolution) selection
9	NOT USED
0	Profile

**Table 3-1. CD Drive Motherboard DIP Switch Functions**

Table 3-2 below shows the settings of motherboard switches 1-4 for the full range of current settings. The values shown in the tables are two-phase-on levels, and are nominal values in that they depend on motor inductance. *When selecting the current, be sure not to exceed the current rating of the motor.*

**CURRENT PROGRAMMING (SWITCHES 1-4)**

In half-step mode, the one-phase-on current is approximately 35%

greater than the level with two phases on, giving a similar electrical power into the motor. *Remember, if permanent square-off is selected, there will be a significant increase in average motor current at low speeds (see below).*

At standby (when the motor is stationary), the current is automatically reduced. This reduction depends on the current setting, and is at 50% when the drive is set to its full current. When the drive is set at its minimum current, the standby current is approximately 80% of the regulated current.

Current		DIP Switch Settings			
CD35/35M	CD25/25M	1	2	3	4
6.5A	3.25A	OFF	OFF	OFF	OFF
6.0A	3.00A	ON	OFF	OFF	OFF
5.5A	2.75A	ON	ON	OFF	OFF
5.0A	2.50A	OFF	OFF	ON	OFF
4.5A	2.25A	OFF	ON	ON	OFF
4.0A	2.00A	OFF	OFF	OFF	ON
3.5A	1.75A	ON	ON	OFF	ON
3.0A	1.50A	ON	ON	ON	ON

**Table 3-2. Motor Current DIP Switch Settings (Full Range)**

**CURRENT PROFILE**

In the half-step mode, a two-level current profile is used at low speeds to equalize torque on alternate steps. Figure 3-2 illustrates this current profile with A and B representing the two-phase-on condition, and C representing the one-phase-on condition. When two phases are energized, the maximum current levels for CD25 and CD35 are 3.25A and 6.5A respectively. These current levels are increased in the one-phase-on condition to 4.6A and 9.2A, respectively, to help maintain the torque during intermediate steps.

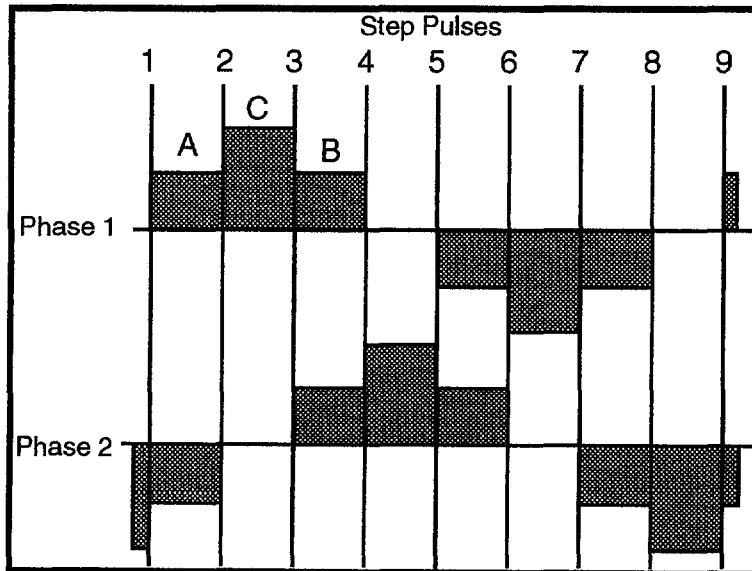

**Figure 3-2. Normal Current Profile (Half-step Mode)**

**SQUARE-OFF  
(SWITCH 5)**

The function of the square-off circuit is to maintain torque output in the middle speed range when motor current usually falls off due to winding inductance. As illustrated in Figure 3-3, the two-phase-on current is squared-off to the one-phase-on level at 3,200 half-steps/sec.

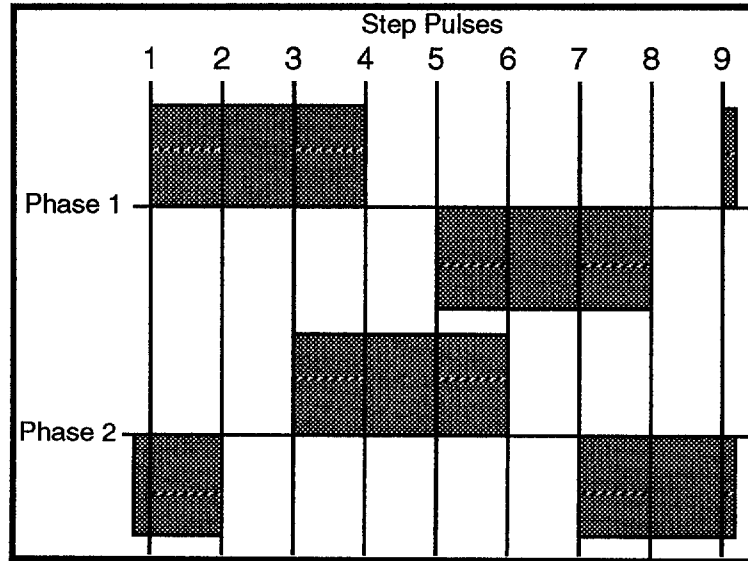

**Figure 3-3. Current Profile with Square-off**

All CD drives have switch 5 factory-set to OFF. Switch 5 is used in conjunction with switch 0 (Profile) to set the current profile in the half-step mode according to Table 3-3.

DIP Switch Settings		Current Profile Mode
5	0	
OFF	OFF	Automatic Square-off*
OFF	ON	No Square-off
ON	ON	Permanent Square-off

\* Factory Setting

**Table 3-3. Square-Off DIP Switch Settings**

In automatic square-off mode (both switches OFF), the drive will not square-off until approximately 3,000 half steps/sec. You can establish permanent square-off by turning ON DIP switches 5 and 0. This significantly increases low-speed torque; however, it also increases motor noise, operating temperature, and resonance. Consequently, *this setting should be used with discretion*. Square-off is logically inhibited at standstill to prevent overheating.

If your drive is equipped for mini-stepping, make sure DIP switch 5 is in the OFF position. Selecting permanent square-off in a mini-step mode effectively returns the drive to the full-step current profile.

**ANTI-RESONANCE  
(SWITCH 6)**

Turning this switch ON inhibits the anti-resonance circuit, providing more torque at lower speeds. The anti-resonance circuit is automatically disabled at a preset speed which is normally 500 half-steps/second. However, *inhibiting anti-resonance increases the likelihood of a stall condition*. This switch is factory-set to the OFF position.

**MODE SELECTION  
(SWITCHES 7 & 8)**

Table 3-4 shows the factory-set and optional operating mode (resolution) settings of DIP switch 7 and 8.

Switch Settings		Operating Mode	Resolution (with a 200 step/rev motor)
7	8		
ON	OFF	Full-step	200 steps/rev
OFF	OFF	Half-step*	400 steps/rev
OFF	ON	1/5-step	1000 steps/rev
ON	ON	1/10-step**	2000 steps/rev

\* Factory Setting for CD25 and CD35

\*\* Factory Setting for CD25M and CD35M

**Table 3-4. Mode Selections using DIP Switches 7 and 8**

NOTE: The 1000- and 2000-step/rev modes can be used only with CD25M and CD35M drives, and Jumper LK1 on the inside of the CD drive motherboard is set to position B (see Figure 3-2).

**SWITCH 9**

THIS DIP SWITCH IS NOT USED.

**PROFILE (SWITCH 0)**

Switch 0 is used in conjunction with switch 5 to set the current profile. Switch 0 and switch 5 are factory-set to the OFF position,

providing automatic square-off.

**Changing  
Components**

The following sub-paragraphs discuss methods of changing drive functions by changing resistors on the CD drive motherboard.

**ANTI-RESONANCE  
DROPOUT SPEED**

This speed is normally 500 half-steps/sec and is determined by resistor R8 on the motherboard (see Figure 3-4). The value of R8 is normally 47k $\Omega$ . You can double the dropout speed by halving the resistor value. *Do not use a value lower than 22k $\Omega$ .*

**SQUARE-OFF**

The square-off speed is determined by resistor R2 on the drive motherboard (see Figure 3-4). The standard value of R2 is 33k $\Omega$ . By doubling the resistor value, you can double the square-off speed. *Do not use a value lower than 33k $\Omega$ .*

**COMPONENT  
LOCATIONS**

CD drive motherboard resistor locations are illustrated in Figure 3-4.

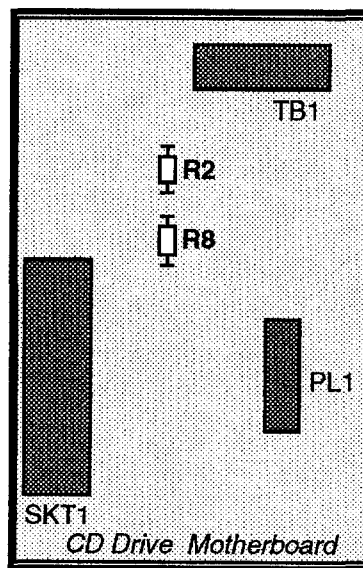

**Figure 3-4. Locations of Motherboard Resistors R8 and R2**

**MS20 DIP Switch  
Settings**

CD25M and CD35M drives are fitted with the MS20 mini-stepping card. The MS20 card has an 8-position DIP switch visible from the front of the drive when the front panel is removed (see Figure 3-5). This switch determines the current profile in the mini-step mode. The optimum profile depends on the type of motor you are using. The switch is capable of producing 64 different profiles. The card has been programmed with a selection of profiles that have been derived theoretically.

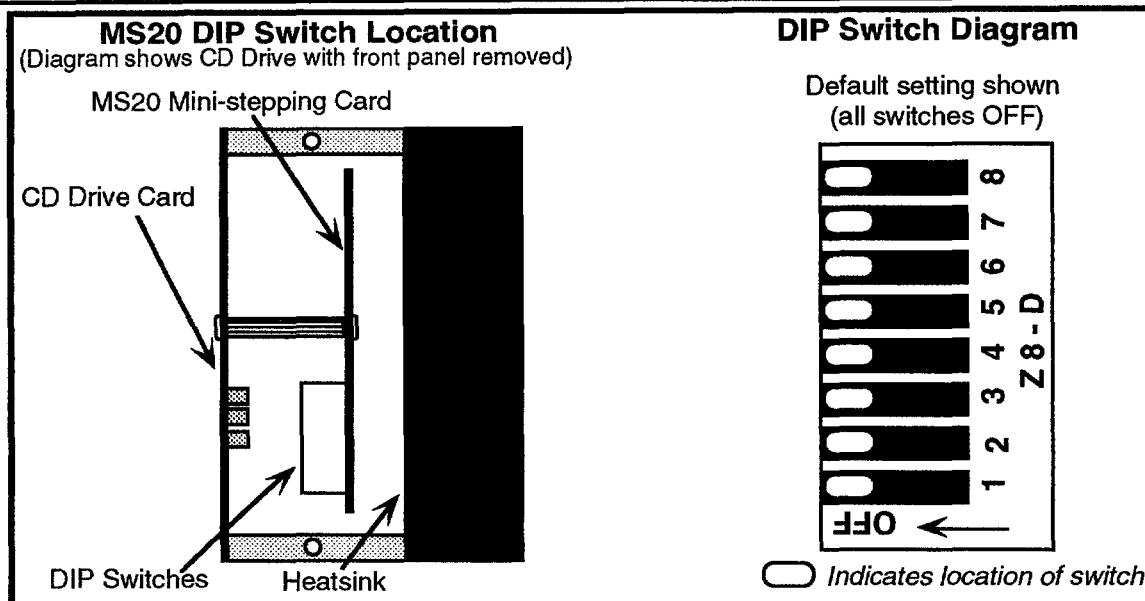

**Figure 3-5. MS20 DIP Switch Location & Default Setting**

Switches 1 - 8 are factory-set to the OFF position, providing a sinusoidal current profile (see Figure 3-6). Use switches 2 - 6 to set an increasing binary number which will cause the profile to progressively *fill out* from a sinewave. By turning switch 7 ON and increasing the binary number in switches 2 - 6, you can trim the profile towards a triangular (*trimmed*) shape. In practice, this is more useful than the *filled out* profile. Switches 1 and 8 should be left permanently OFF. See Table 3-5 for switch position examples;

DIP Switch Position								Profile
1	2	3	4	5	6	7	8	
OFF	OFF	OFF	OFF	OFF	OFF	OFF	OFF	Sinewave*
OFF	ON	OFF	OFF	OFF	OFF	OFF	OFF	Slight Fill-out
OFF	OFF	OFF	OFF	OFF	ON	OFF	OFF	Moderate Fill-out
OFF	ON	ON	ON	ON	ON	OFF	OFF	Maximum Fill-out
OFF	ON	OFF	OFF	OFF	OFF	ON	OFF	Slight Trimming
OFF	OFF	OFF	OFF	OFF	ON	ON	OFF	Moderate Trimming
OFF	ON	ON	ON	ON	ON	ON	OFF	Maximum Trimming

\* Factory Setting

**Table 3-5. MS20 DIP Switch Examples**

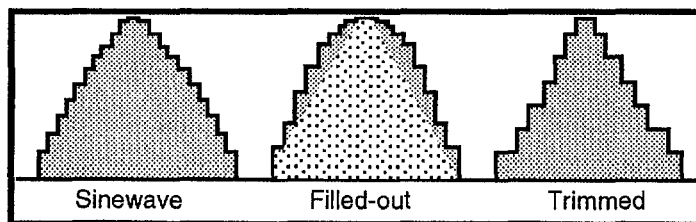
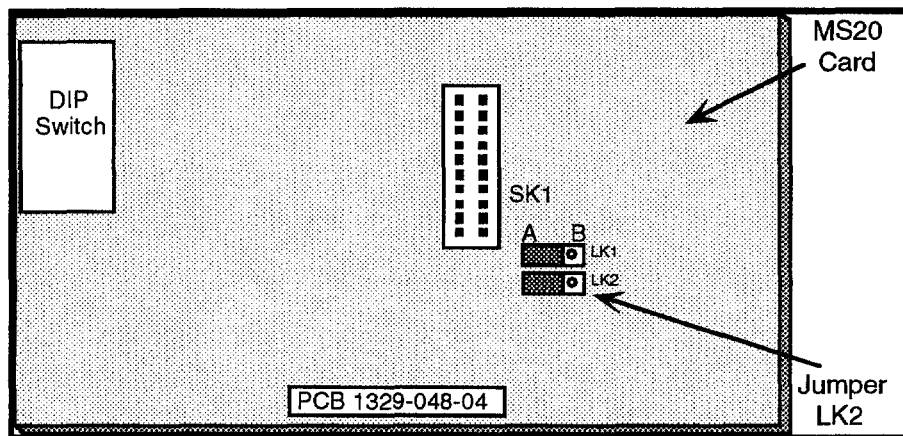

**Figure 3-6. Mini-stepping Current Profiles**

Leave Jumper LK1 on the MS20 card in default position **A** (see Figure 3-7). Normally, you would leave Jumper LK2 in default position **A**. Moving Jumper LK2 to position **B** will select a sinusoidal profile at standstill; with some motors, this will give better static positioning than a filled-out or trimmed profile.

### CAUTION

To access Jumper LK2 on the MS20 mini-stepping card, you must first remove the drive heatsink and the MS20 card. If the CD drive system is already operating properly, do not change Jumper LK2.



**Figure 3-7. Location of Jumper LK2 on the MS20 Mini-stepping Card**

Choosing the optimum profile for a given motor is best carried out with equipment that will accurately measure shaft position and torque (such as a high-resolution encoder and a torque meter, respectively). Since such equipment is seldom available, you can use the following empirical method to get acceptable results:

*NOTE: For most applications, the factory default settings are suitable. The following steps are necessary only if the factory default settings provide unacceptable results.*

### WARNING

**Make sure the power to the CD drive system is turned off before adjusting the drive.**

- STEP 1** Remove the front panel to access the MS20 DIP switch.
- STEP 2** Make sure all DIP switches are OFF (factory-setting). This setting provides a sinusoidal profile.
- STEP 3** Attach a piece of tape or a white cable tie to the motor shaft, leaving one end sticking out to function as a pointer.



**STEP 4** Turn on the power to the CD drive system.

**STEP 5** Set up the indexer to perform a move with the following parameters:

- Mode = Continuous
- Acceleration = 1 rps<sup>2</sup>
- Velocity = 0.2 rps

Immediately after issuing the **GO** or **START** command, the motor shaft will rotate continuously at 0.2 rps. As the shaft rotates, look at the pointer to visually discern whether the step sizes are all similar, or if there is a cyclic variation in step size.

**STEP 6** Slowly increase the velocity in small increments (increments of  $\approx 0.2$  rps). As you increase the motor speed, listen to the motor. This will give you an idea of the relative torque produced on successive steps. A cyclic pulsing sound implies associated torque variations.

If you hear a cyclic pulsing sound or if you can see a cyclic variation in step size, you need to trim the current profile. If you do not witness these cyclic variations, you do not need to adjust the DIP switches; stop here, turn off the power to the drive, and replace the drive front panel..

**STEP 7** To trim the current profile, turn off the power and adjust the DIP switches using Table 3-5 as a guide. Repeat steps 4 through 7 until you achieve a usable profile range (when you can no longer visibly or audibly detect the cyclic step and torque variations). It is best to achieve the smoothest rotation, rather than the best static positioning. If your application requires significant torque from the motor, repeat these steps with the motor loaded.

---

### Setting Drive Functions (CD20, CD30 & CD40 drives only)

This section discusses setting drive functions for CD20, CD30 and CD40 drives only. Drive functions are set by means of jumpers and resistors. These are factory-set to provide optimum operation in most applications. You may, however, need to alter these settings to satisfy the particular operating requirements for your application.

To change the settings for the CD20, CD30 and CD40 drives, you must access the drive translator card.

#### **WARNING**

**Do not remove the drive modules while power is applied to the rack.**

**STEP 1** Remove the four screws securing the drive to the rack. Then pull the drive from the rack. **NOTE:** When re-installing the drive, make sure the drive follows the guides in the rack. This will ensure proper connection to the motherboard.

- STEP 2** Since considerable force is required to loosen the heatsink screws, place the drive on a soft, padded, static-free surface.
- STEP 3** Remove the eight screws securing the heatsink to the heat shunt rails, then remove the heatsink. When replacing the heatsink, use silicone grease on the mating surfaces of the heat shunts.
- STEP 4** Remove the two screws that secure the translator card to the drive card and unplug the translator card.
- Stepping Mode (Resolution)** You can use Jumper LK3, located on the translator card, to select either full-step or half-step modes. The CD drive system is shipped with Jumper LK3 not installed, selecting the half-step (400 steps/rev) mode. Installing Jumper LK3 selects the full-step (200 steps/rev) mode. Refer to Figure 3-8 for the location of Jumper LK3. *NOTE: Make sure Jumper LK1 on the inside of the CD drive motherboard is set to position A.*
- Energize** To use the shutdown facility and the X-Code Shutdown (**ST**) command, remove Jumper LK1 on the translator card (Refer to Figure 3-8.) The system is shipped with Jumper LK1 installed. Leaving LK1 installed causes the drive to be permanently energized and the **ST** command will have no effect.
- De-energize at Standstill** Installing Jumper LK2 on the translator card causes the drive to automatically de-energize at standstill. The system is shipped with Jumper LK2 not installed, causing the drive to remain energized at standstill. Refer to Figure 3-8.
- Current Programming** *NOTE: Since CD20, CD30 and CD40 drives do not use the motherboard DIP switches (0 - 9), make sure they are all set to the OFF position.*
- The regulated current may be reduced by installing a resistor in location R59 on the CD translator card (see Figure 3-8 for resistor location). The CD drive system is shipped with R59 not installed, thus providing an open circuit (maximum current output).

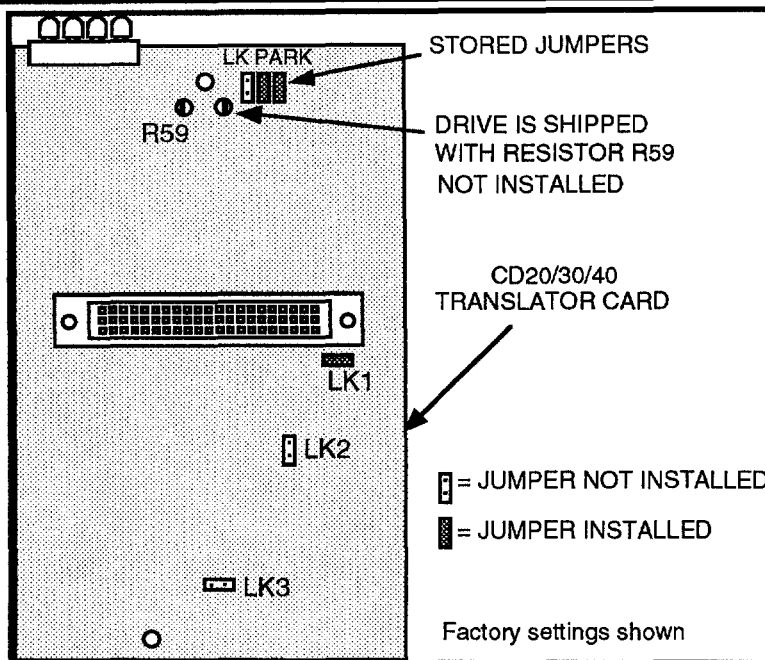

**Figure 3-8. Location of CD20/30/40 Drive Jumpers and Resistor R59**

Table 3-6 shows resistor values for various motor currents. The values shown are two-phase-on levels, and are nominal in that they depend on motor inductance. *When selecting the current, be sure not to exceed the motor's current rating.*

In half-step mode, the one-phase-on current is approximately 35% greater than the level with two phases on, giving a similar electrical power into the motor.

At standby (when the motor is stationary), the current is automatically reduced. This reduction depends on the current setting, and is at 50% when the drive is set to its full current. When the drive is set at its minimum current, the standby current is approximately 80% of the regulated current.

Value of R59	Current (CD20 Drive)	Current (CD30 Drive)	Current (CD40 Drive)
Open circuit*	2.8A	5.6A	9.3A
8.2kΩ	2.4A	4.8A	8.0A
3.3kΩ	2.0A	4.0A	6.6A
2.2kΩ	1.7A	3.4A	5.6A
1.5kΩ	1.4A	2.8A	4.6A
1.0kΩ	1.1A	2.2A	3.6A

\* Factory Setting (no resistor installed)

**Table 3-6. Motor Current R59 Values**

---

**Environmental Considerations**

The CD drive system should be operated in temperatures from 0 to 50°C (32 to 122°F) and at a relative humidity between 0 and 95% (non-condensing). Make sure the system is stored in temperatures from -40°C to 85°C (-40°F to 185°F).

---

**Enclosure Considerations**

You should install the CD drive system in an enclosure to protect it against atmospheric contaminants such as oil, moisture, and dirt. Ideally, you should install the system in a rack cabinet. The National Electrical Manufacturers Association (NEMA) has established standards that define the degree of protection that electrical enclosures provide. The enclosure should conform to NEMA Type 12 standards if the intended environment is industrial and contains airborne contaminants. Proper layout of components is required to ensure sufficient cooling of equipment within the enclosure.

---

**Transformer Mounting**

The transformer models used with the CD drive system (models TO73 and TO92) may be mounted in the cabinet or, if you are not using a cabinet, close to the CC rack system. Ensure that the transformer is located where it does not have excessively long leads and does not interfere with the CD drive system operation and electrical connections. Transformer dimensions and weights are provided in Chapter 4, Hardware Reference.

**WARNING**

**Do not mount the transformer where it is likely to be touched by personnel. Touching the wiring studs while the transformer is energized can cause serious injury.**

---

**System Connections**

If you have set all the CD drive functions, you are now ready to perform the final wiring for your system. Pinouts on the drive motherboard and the PM1200 motherboard are illustrated in Chapter 4, Hardware Reference. *NOTE: If you are using the CD drive without a motherboard, refer to Chapter 2, Getting Started, for stand-alone drive wiring instructions.*

**WARNING**

**Ensure that AC power is disconnected before you perform any wiring. NEVER disconnect the motor with power applied to the drive.**

---

**Wiring Guidelines**

Proper grounding of electrical equipment is essential to ensure the safety of personnel. You can reduce the effects of electrical noise due to electromagnetic interference (EMI) by grounding. A good source of information on grounding requirements is the National Electrical Code published by the National Fire Protection Association

of Boston, Massachusetts.

In general, all components and enclosures must be connected to earth ground to provide a low impedance path for ground fault or noise-induced currents. All earth ground connections must be continuous and permanent. We recommend using a central earth stud mounted on the rack end-plate or close to it. AC ground, the transformer shield, the rack 0V bus, and the enclosure metalwork should all be connected to this stud. In particular, you should connect the rack 0V bus with a 18AWG (1mm<sup>2</sup>) cable kept as short as possible.

---

### **Transformer Connections**

Depending on your application the CD drive system is equipped with transformer model TO73 (1200VA) or TO92 (600VA). Each of these transformers for the CD drive system has a four-winding primary arrangement. Chapter 2, Getting Started, shows the transformer primary connections for 120V and 240V AC.

If your application requires different supply voltages refer to Chapter 4, Hardware Reference, to select the proper wiring arrangement.

Refer to Chapter 2, Getting Started, for instructions on connecting the transformer to the PM1200 motherboard.

---

### **Indexer Connections**

Refer to Chapter 2, Getting Started for instructions on connecting the indexer to the CD drive motherboard.

---

### **Auxiliary Indexer Connections**

PL1 on the back of the CD drive motherboard is an 8-pin ramped connector providing optional connections for the eight drive control signals (see Figure 3-9).

These inputs are for using non-TTL indexers and clock cards (MC1, BC7, RC9, etc.).

If you are not using a Digiplan or Compumotor indexer with standard cables, it may be easier for you to use the ramp connector (PL1). The electrical specifications for this connector are provided in Chapter 5, Hardware Reference. The inputs on PL1 are not compatible with Digiplan and Compumotor TTL indexers.

*NOTE: Caution must be used since these inputs are not optically isolated and are therefore more noise-sensitive than the inputs on the 25-pin indexer connector (SKT1).*

Jumper cables are available from Digiplan (200mm cable: p/n 200MM JUMPER, or 400mm cable: p/n 400MM JUMPER). Refer to Figure 3-9 for the PL1 auxiliary drive connector location and pinouts.

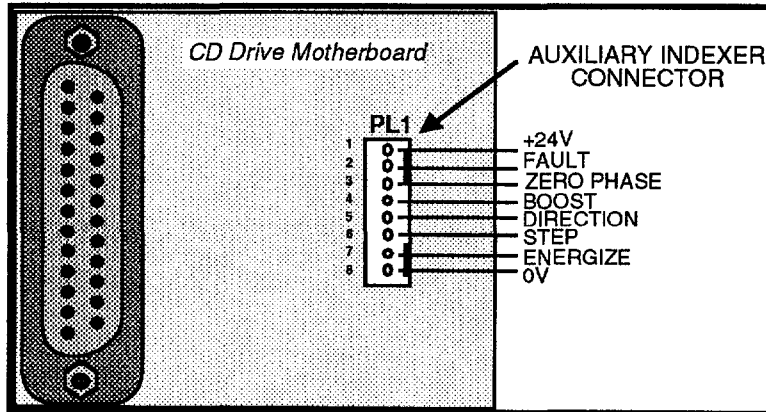

**Figure 3-9. PL1 Auxiliary Indexer Connector**

**+24 Volts  
(Pin 1)**

This terminal may be used as an output to provide +24V from the CD drive to external control circuitry. Current drawn must be limited to a total of 500mA.

**Fault  
(Pin 2)**

This is a composite output signal which goes high in the event of an overload, supply failure or over-temperature fault. It is driven by an open-collector transistor and should be pulled up by an external resistor when the signal is required (see Figure 3-10). The resistor should be returned to a voltage no higher than 24V, and should not allow more than 15mA to flow when the output is low.

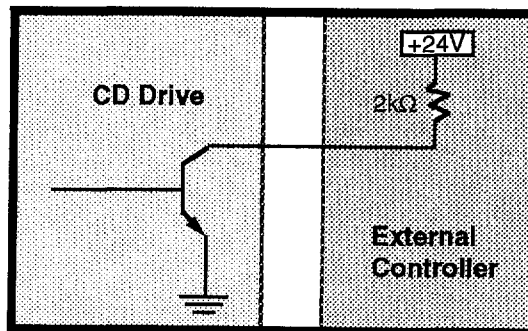

**Figure 3-10. Fault Output Example**

**Zero Phase  
(Pin 3)**

Zero phase corresponds with current flowing from positive (+) to negative (-) in motor phase A, and from negative to positive in motor phase B. The zero phase output is low when the translator is in its primary state. For example, this occurs every 8 steps in the half-

step (400 step/rev) mode; consequently, the signal will go low 50 times per revolution with a standard motor. At power-on, the translator is always reset to the zero phase state. This signal can be used when establishing a mechanical reference or *home* position.

**Boost**  
(Pin 4)

Connecting this input terminal to the 0V terminal increases the motor current by approximately 30%. You can use this function to increase torque at strategic times, such as during acceleration. On the CD25 and CD35, if this input is held low, the current will revert to its normal unboosted level after 5 seconds.

**CAUTION**

**Do not allow an external controller to boost more than 25% of the time, or longer than 5 seconds at any time.**

**Direction**  
(Pin 5)

Taking this input terminal low (connecting it to the 0V terminal) will reverse the direction of motor rotation. The direction should only be changed when the motor is stationary or running within the start/stop speed range.

**Step**  
(Pin 6)

A low-going transition on this input terminal causes the motor to advance one step. The input should remain low for not less than 5 $\mu$ s and not more than 30 $\mu$ s. The maximum step pulse frequency is 18kHz in the full-step mode, 50kHz in the half-step mode, and 100kHz in the mini-stepping mode.

**CAUTION**

**Do not stop the step pulses while it is running above the start/stop speed; this will cause the motor to stall.**

**Energize**  
(Pin 7)

This input terminal enables the motor to be de-energized so that it may be rotated slowly by hand without switching the system off. To use this facility with CD20/30/40 drives, you must first remove Jumper LK1 on the drive translator card. You must connect this input terminal to the 0V terminal in order to energize the motor.

**0V**  
(Pin 8)

Use this terminal as the common return point for the controller signals.

---

**Chapter 4. HARDWARE REFERENCE**

---

**Chapter Objectives**

This chapter is designed to function as a quick-reference tool for the following information:

- System specifications (dimensions & performance)
- Default DIP switch and jumper settings
- I/O connections and specifications

---

**Environmental Specifications**

It is recommended that you operate and store your CD drive system under the following conditions:

- Operating Temperature: 0° to 50°C (32° to 122°F)
- Relative Humidity: 0% to 95% (non-condensing)
- Maximum Heatsink Temperature: 85°C (185°F)
- Storage Temperature: -40° to 85°C (-40° to 185°F)



## System Specifications

Parameter	Value
<b>Amplifiers</b>	
Type	Bipolar recirculating chopper
Motor Resolution	200 or 400 steps/rev ( <i>User-selectable</i> )
CD20, 25, 30, 35 CD25M and 35M	200, 400, 1,000, or 2,000 steps/rev ( <i>User-selectable</i> )
Protection	
Short-circuit	Phase-to-phase and phase-to-ground
Supply fault	If logic or motor supply drops below 17V DC (24VDC nominal), or motor supply exceeds 96V DC
Over-temperature	If heatsink exceeds 85°C (185°F)
Nominal Output Current (Two-phase-on)	
CD20, 25, 25M	3A/phase ( <i>Adjustable with DIP switches for CD25 and CD25M ONLY</i> )
CD30, 35, 35M	6A/phase ( <i>Adjustable with DIP switches for CD35 and CD35M ONLY</i> )
CD40	9A/phase
	<b>NOTE: CD20/30/40 drive output current is adjusted only by changing resistor R59 on the translator card.</b>
Maximum Stepping Rate	Full-Step Mode-18kHz-50 rps Half-Step Mode-50kHz-50 rps 1,000-Step Mode-100kHz-100 rps 2,000-Step Mode-100kHz-50 rps <b>NOTE: The motor may not be capable of these rotational speeds.</b>
Nominal Chopping frequency	
CD20	6kHz
CD30	4kHz
CD40	3kHz
CD25, 25M, 35, 35M	7.5 - 30kHz ( <i>Depends on motor speed</i> )
<b>Command Interface</b>	
CD drive module	
Input impedance	Built-in pull-up resistors (4.7kΩ) to +12V
Input logic level	Low (logic 0) 0 to 2V or short circuit to 0V High (logic 1) +10V to +12V or open circuit
Logic output	Open-collector NPN transistors; low level +1V max. @15mA max., high level +24V max.
CD drive mounted in a CC rack	The step input is a high-going pulse, 5μS min. width. The maximum pulse rate is 100kHz.
Input	Optically isolated and require a TTL-type signal. >3.5VDC high, <0.8VDC low. User-supplied step and direction signals must provide up to 20mA.

<b>Power</b>	
Logic supply voltage (all drives)	+20 to +26VDC
Logic supply current	
CD20	250mA
CD30	400mA
CD40	750mA
CD25, 25M, 35, 35M	280mA
Motor supply voltage	+24 to +85VDC (Absolute limits: +20V to +95VDC)
Current Boost	30% (5 seconds max. duration)
Standby Current Reduction	50% (at max. current); 20% (at min. current)
Drive Fuse (FS1)	CD20, 25, 25M: 5A QB HBC CD30, 35, 35M: 10A QB HBC CD40: 15A QB HBC
<b>Motors</b>	
Type	2-Phase hybrid or permanent magnet (normally 1.8°)
Number of Leads	4, 6, or 8 (5 not suitable)
Minimum inductance	0.5mH
Current range	CD20, 25, 25M; 2.0A - 4.0A; CD30, 35, 35M; 4.0A - 8.0A; CD40; 6-12A

**Table 4-1. CD Drive Specifications**

**Power Supply Specifications**

Parameter	Value
<b>AC Input Power</b>	
Logic Supply	20V RMS @ 3A
Motor Supply	Up to 61V RMS (no load) @ 20A
<b>DC Output Power</b>	
Logic Supply	+24V @ 2A
Motor Supply	Up to +85V @ 15A
<b>Fuse Ratings</b>	
Logic Supply (FS1)	3.15A
Power Dump (FS2)	2A (anti-surge time delay)

**Table 4-2. PM1200B Power Supply Specifications**

**System Pinouts and Connectors**

This section illustrates the pinouts and connectors on the CD drive and PM1200 motherboards.

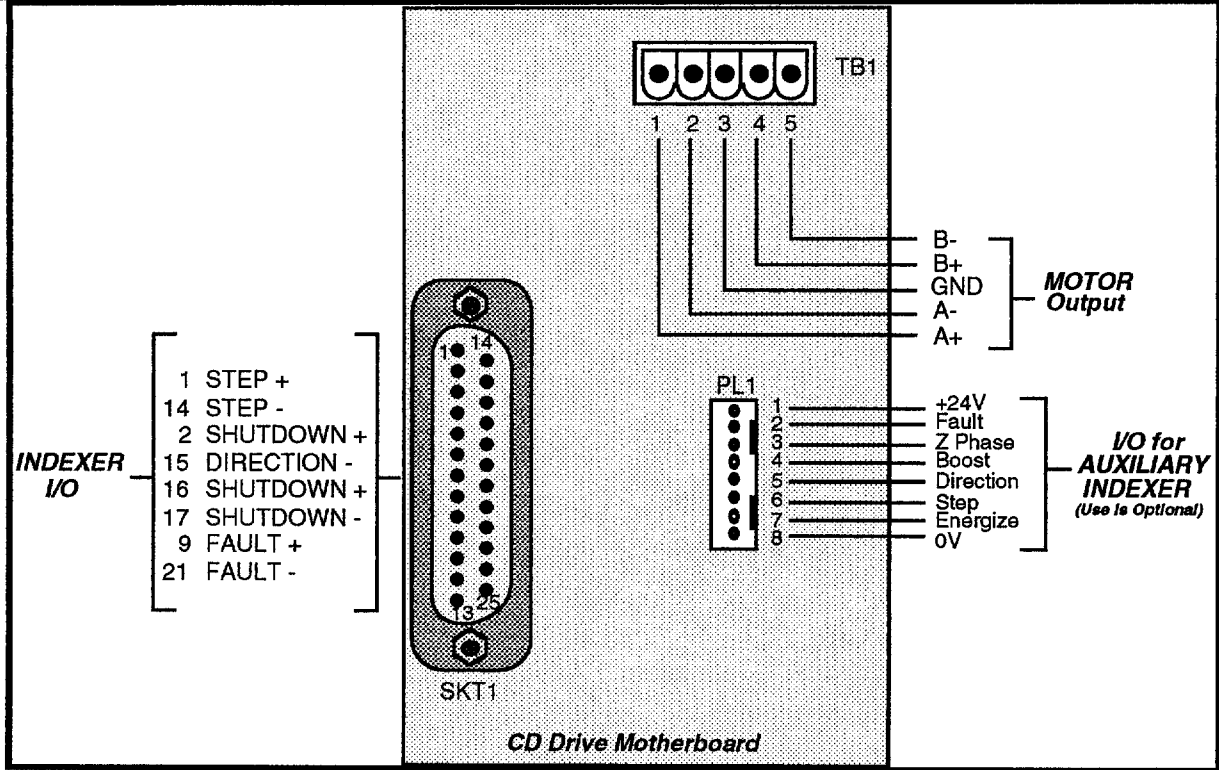

Figure 4-1. CD Drive Motherboard Inputs and Outputs

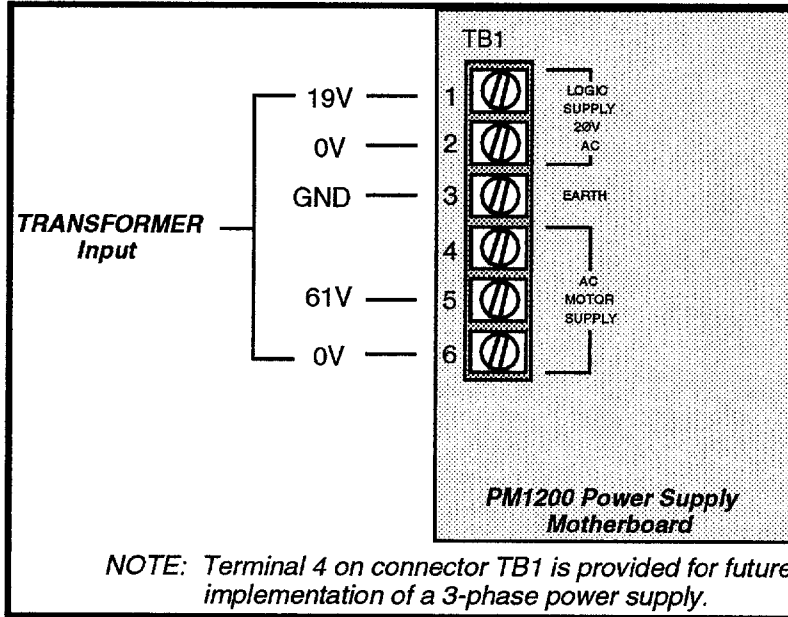

Figure 4-2. PM1200B Power Supply Inputs

**I/O Specifications**

The following tables identify the I/O specifications for the indexer and auxiliary drive connectors on the CD drive motherboard.

**Indexer (SKT1)**

Pin	Name	Type	Input/Output	Current	Voltage
1	Step +	SNK*	Input	20 mA	<0.8V = low >3.5V = high
2	Direction +	SNK*	Input	"	"
9	Fault +	OC**	Output	"	"
14	Step -	GND	Input	"	"
15	Direction -	GND	Input	"	"
16	Shutdown +	SNK*	Input	"	"
17	Shutdown -	GND	Input	"	"
21	Fault -	GND	Output	"	"

\* Sinking input. Optically isolated. Requires a ground to activate.

\*\* Open collector output. Not optically isolated.

NOTE: All other pins are not connected

**Table 4-3. Indexer Input Specifications**

**Aux. Indexer (PL1)**

Pin	Name	Type	Input/Output	Current	Voltage
1	+24V	POWER	Output	-----	24VDC
2	Fault	OC*	Output	15mA max	12VDC
3	Zero Phase	OC*	Output	15mA max	"
4	Boost	SNK**	Input	2.5mA	"
5	Direction	SNK**	Input	2.5mA	"
6	Step	SNK**	Input	2.5mA	"
7	Energize	SNK**	Input	2.5mA	"
8	0V	POWER	-----	-----	0VDC

\* Open collector output. Not optically isolated.

\*\* Sinking input. Not optically isolated. Requires a ground to activate.

**Table 4-4. Auxiliary Drive I/O Specifications**

**I/O Descriptions****Indexer Inputs**

Indexer inputs (compatible with Digiplan indexers) are transmitted via connector SKT1 on the CD drive motherboard. These inputs are optically isolated on the motherboard and are intended to be driven differentially from 5V logic levels. Figure 4-3 represents the step and direction input circuit. In the shutdown input circuit, the capacitor is omitted and the resistor value is increased to 270k $\Omega$ . The input descriptions are provided below.

**STEP+ & STEP-**

A pulse on these inputs (pins 1 and 14) causes the motor to step on a low-to-high transition. These inputs should remain high for at least 5 $\mu$ s. Make sure you set the pulse width of the indexer that you are using to at least 5 $\mu$ s. Consult your indexer user guide for

instructions on how to change the pulse width.

### DIRECTION+ & DIRECTION-

These inputs (pins 2 and 15) control the direction of the motor shaft rotation. Changing the level of these inputs changes the direction in which the shaft moves.

### SHUTDOWN+ & SHUTDOWN-

These differential inputs (pins 16 and 17) are used to energize and de-energize the motor. To remotely de-energize the CD20/30/40 drive, you must first remove the energize jumper, LK1, on the drive translator card. When the shutdown+ input is taken high, the drive is de-energized and the motor shaft may be rotated **slowly** by hand. *NOTE: Back-driving the motor may overload the power dump circuit in the power supply.* Taking the shutdown input high resets a fault condition, and the drive is re-energized when the input returns low.

### Motor Outputs

Refer to Figure 4-1 for motor pinouts and colour codes. Refer to Table 4-1 for motor compatibility.

### Auxiliary Indexer I/O

PL1 on the back of the drive motherboard is an 8-pin ramp connector providing connections for the eight drive control signals (see Figure 4-1).

If you are not using a Digiplan or Compumotor indexer with standard cables, it may be easier for you to use the ramp connector (PL1). Refer to Table 4-4 for electrical specifications.

*NOTE: Caution must be used, since these inputs are not optically isolated and are therefore more noise-sensitive than the inputs on the 25-pin indexer connector (SKT1).*

---

### I/O Wiring Diagrams

Figure 4-3 illustrates the typical drive input circuit. Figure 4-4 illustrates the typical drive output circuit.

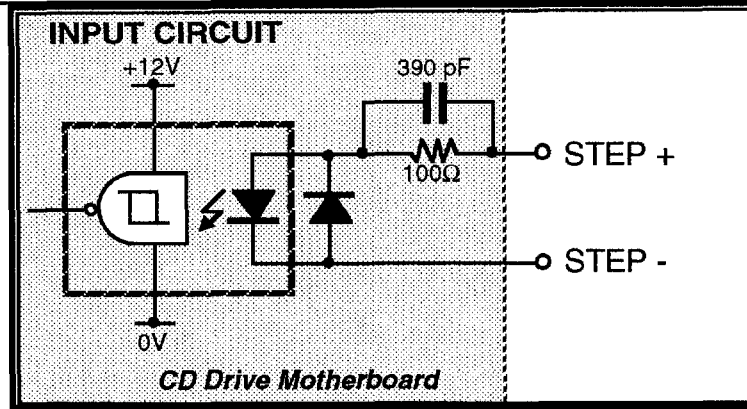

Figure 4-3. Typical CD Drive Input Circuits

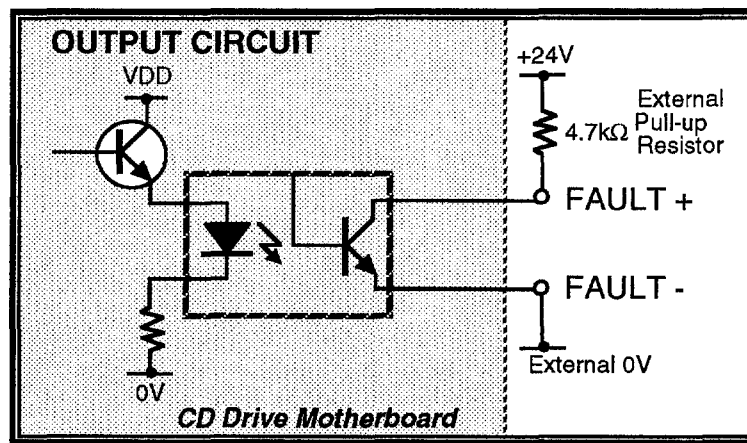

Figure 4-4. Typical CD Drive Output Circuits

**Factory Default Settings**

Table 4-5 below provides the CD drive factory default settings. If the factory settings are not appropriate for your application, refer to Chapter 3, Installation, for instructions on adjusting the appropriate drive and motherboard DIP switches and jumpers.

## 38 CD STEPPER DRIVE & CC RACK SYSTEM USER GUIDE

Feature	Default Setting	Function Selected
<b>Motherboard Jumper</b> LK1	Position <b>A</b> (CD20, 25, 30, 35 & 40) Position <b>B</b> (CD25M and 35M)	200/400 step/rev operation 1,000/2,000 step/rev operation
<b>Motherboard DIP Switch*</b> 1 - 4	<b>CD25/35</b> OFF	3.A Output Current (CD25/25M) 6A Output Current (CD35/35M)
5	OFF	Automatic Square-off
6	OFF	Anti-resonance Enabled
7&8	OFF	400 step/rev Mode (CD25/35) 2000 step/rev Mode (CD25M/35M)
9	---NOT USED (OFF)---	Not Used
Ø	OFF	Automatic Square-off
<b>MS20 Jumpers</b> LK1 LK2	Position <b>A</b> Position <b>A</b>	<i>Future Use (Do not adjust.)</i> Profile at standstill = profile moving
<b>MS20 DIP Switch</b> 1 - 8	All OFF	Sinusoidal Current Profile
<b>CD20/30/40 Jumpers</b> (on translator card) LK1	Installed	Drive is permanently energized; Shutdown command will not work
LK2	Not Installed	Drive remains energized at standstill
LK3	Not Installed	Half-step (400 step/rev) mode
<b>CD20/30/40 Resistor</b> (on translator card) R59	Not Installed (open circuit)	Maximum current: CD20: 3A CD30: 6A CD40: 9A

\* All motherboard DIP switches must be set to OFF for CD20/30/40 Drives (DIP switch functions are not used).

**Table 4-5. CD Drive Factory Default Settings**

### Transformer Wiring

Depending on your application, the CD drive system is equipped with transformer model TO73 (1200VA) or TO92 (600VA). The PM1200B power supply receives AC from the transformer and generates DC to the drive. Each of these transformers for the CD drive system has a four-winding primary arrangement. Use Table 4-6 to select the appropriate wiring arrangement.

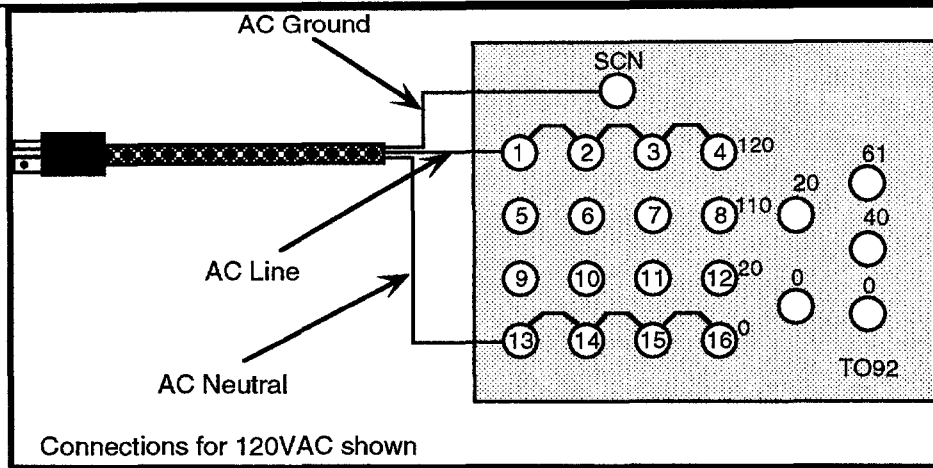

Figure 4-5. Transformer Wiring

Input Voltage	Connect AC Line to:	Connect AC Neutral to:	Connect Studs:
100	1	9	1, 2, 3 & 4; 9, 10, 11 & 12
110	5	13	5, 6, 7 & 8; 13, 14, 15 & 16
120	1	13	1, 2, 3 & 4; 13, 14, 15 & 16
200	1	10	9 & 2; 11 & 4; 1 & 3; 10 & 12
220	5	14	13 & 6; 15 & 8; 5 & 7; 14 & 16
230	1	14	1 & 3; 13 & 6; 15 & 8; 14 & 16
240	1	14	1 & 3; 13 & 2; 15 & 4; 14 & 16
360	5	12	9 & 6; 10 & 7; 11 & 8
380	5	16	9 & 6; 10 & 7; 11 & 8
400	1	12	9 & 2; 10 & 3; 11 & 4
420	1	16	9 & 2; 10 & 3; 11 & 4
440	5	16	13 & 6; 14 & 7; 15 & 8
460	5	16	13 & 6; 14 & 3; 15 & 4
480	1	16	13 & 2; 14 & 3; 15 & 4

Table 4-6. Default and Optional Transformer Settings  
Dimensional Drawings

CC Rack



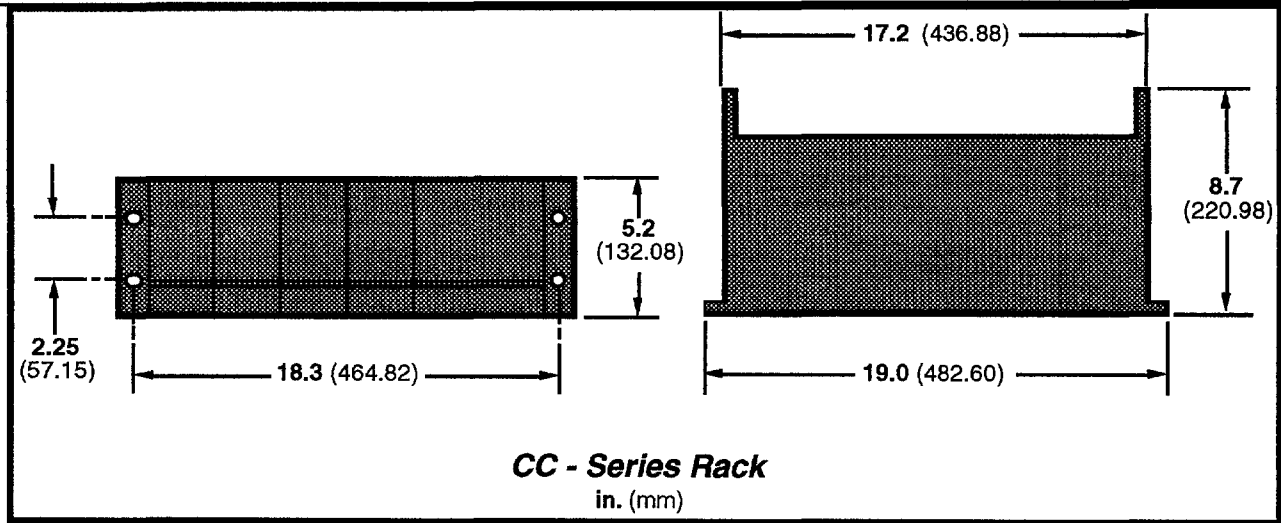

Figure 4-6. CC Rack Dimensions

Transformers

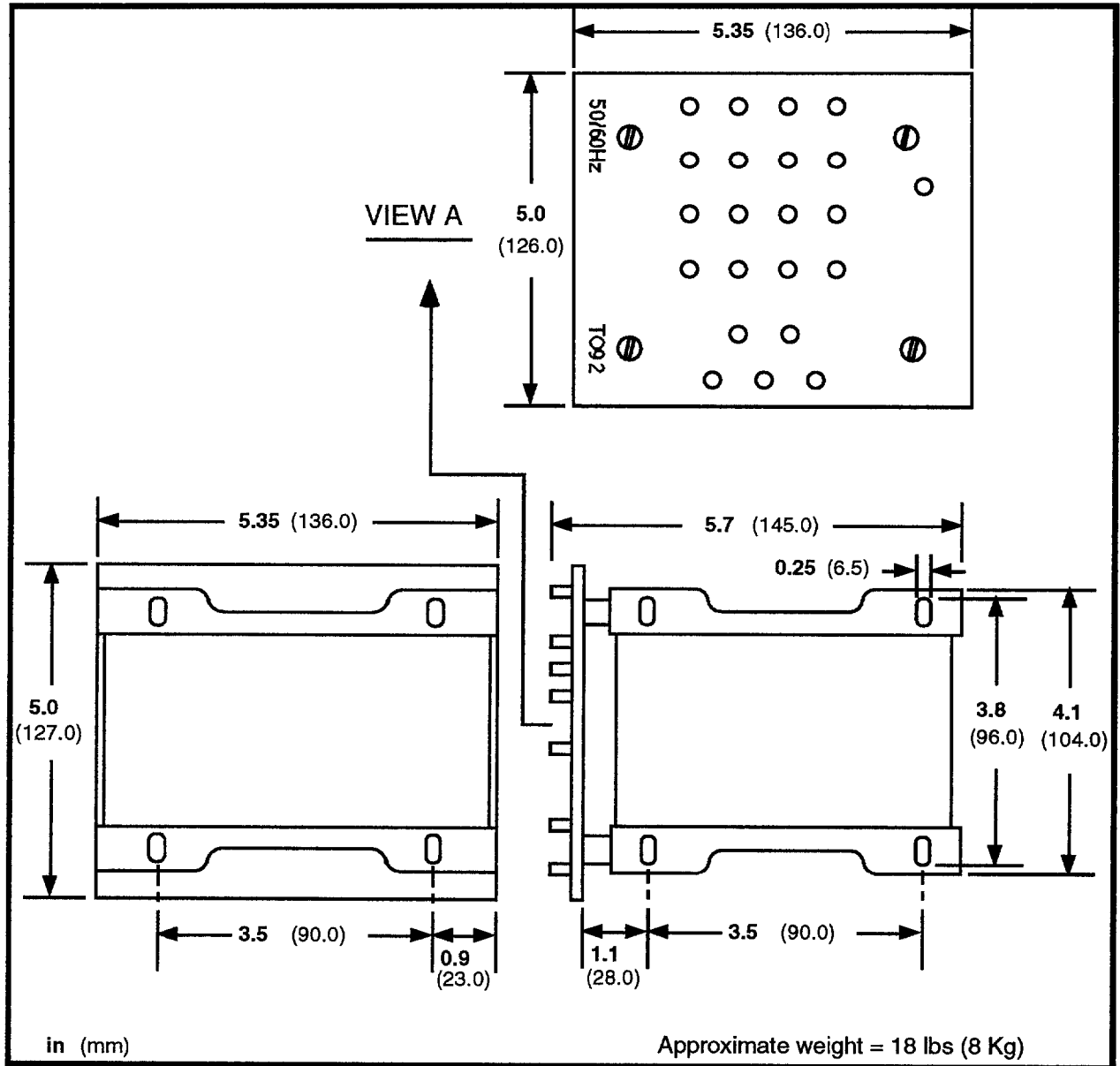

Figure 4-7. Transformer Model TO92 Dimensions

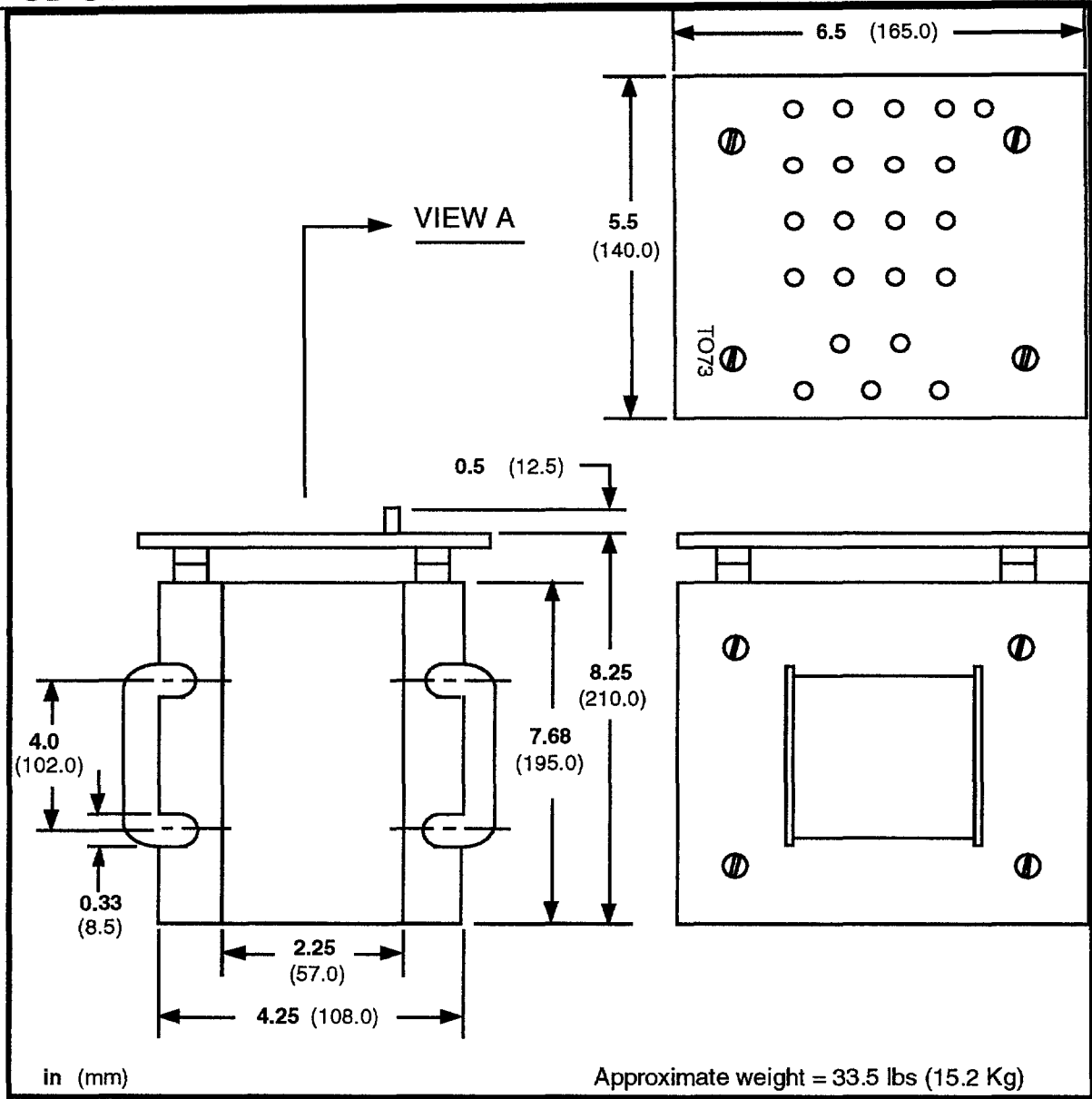

Figure 4-8. Transformer Model TO73 Dimensions

---

## Chapter 5. MAINTENANCE & TROUBLESHOOTING

---

### Chapter Objectives

The information in this chapter will enable you to do the following:

- Maintain the system's components to ensure smooth, efficient operation
  - Isolate and resolve system hardware and software problems
- 

### Maintenance

#### Spare Parts Table

Table 5-1 provides a list of spare parts to use with the CD drive system.

Function	Part Number
Transformer Power Cable	71-010680-01 <b>USA only</b>
Transformer Jumper Cable	71-010956-01 <b>USA only</b>
Transformer-to-MB Cable	71-010676-01 <b>USA only</b>
CD Drive Motherboard Kit	CDCMBKIT
Power Supply Motherboard Kit	PMCMBKIT
Power Supply	PM1200B
Drives as required	CD20/25/25M/30/35/35M/40

**Table 5-1. Recommended Spare Parts for the CD Drive Rack-mount System**

---

#### Motor Maintenance

You should periodically inspect all mechanical parts of the motor to ensure that no bolts or couplings have become loose during normal operation. This will prevent minor defects from developing into more serious problems.

You should also inspect the motor cable or leads for signs of wear. This inspection interval is duty-cycle, environment, and travel-length dependent. You should not apply excessive tensile force to the cable. Do not bend the cable beyond a one-inch radius of curvature during normal operation. Tighten all cable connectors.

---

#### Drive Maintenance

Check that the drive heatsink is free of particles and has a free flow of air over its entire surface. Enclosures must be connected to earth ground to provide a low-impedance path for ground-fault or noise-induced currents; check the security of all ground connections.

**Troubleshooting** This section discusses methods to identify, isolate, and resolve problems that may occur with your CD drive system.

---

### Motor Fails to Move

Test the motor to see if it has holding torque. If there is no holding torque, here are some possible causes:

- There is no AC power.
- Current selection DIP switches are not set properly (see the motor current selection table in Chapter 5, Hardware Reference). *NOTE: For CD20/30/40 drives, ensure that the value of resistor R59 is appropriate for the motor used.*
- There are bad connections or bad cables. Disconnect the power connector, then use an ohm meter to monitor continuity between the motor and drive.
- The drive may not be connected properly to the motherboard. Make sure the drive is securely plugged into the DIN connector on the inside of the motherboard.
- The shutdown input may be active.
- The drive supply fuse may be blown. Disconnect AC power, remove the drive from the rack, and inspect the line fuse on the inside of the CD drive motherboard. **If the fuse is blown, return the system for repair.**

If the unit has holding torque and the motor shaft still fails to move, here are some probable causes:

- The limit switches have been tripped or are faulty. Make sure that your limit switches are OFF or that the limits are disabled.
- The load is jammed. You should *hear* the drive attempting to move the motor. Remove AC power and verify that you can move the load manually away from the point of the jam.
- Indexer parameters are incorrectly set up. If certain parameters are out of range or are missing, the motor will not move when you issue the GO or START command.

The following are additional troubleshooting techniques:

- Check the motor for damage. Also check the motor leads/cable to see if they are damaged or shorted. These conditions may cause the drive to fault.
- Check the motor and cables to make sure that shorts do not exist between phases or earth GND. The resistance across each

motor phase should be consistently low. The resistance between motor phases and between each phase and earth ground should be very high.

***Fault LEDs***

There are three protection systems built into the CD drive, any of which may cause the drive to shut down. Three red LEDs on the front panel of the CD drive indicate which of the following fault conditions exist.

- *Overload:* This LED normally indicates a short circuit in the motor. Use a meter to make sure that there is not a short circuit between phase A and B, or to earth ground. Remove AC power, disconnect the motor and switch on again. If the overload LED still comes on, the drive is damaged.
- *Supply Failure:* The supply protection circuit shuts down the drive if one of the following conditions exist:
  - Motor or logic supplies fall below approximately 17V
  - Motor supply rises above 96V
  - Internally-derived voltage rails fail
- *Over-temperature:* This LED lights if the drive is overheating (heatsink temperature is above 85°C). You may consider cooling the rack cabinet or drive. Installing a fan nearby may help the problem.

The drive fault output goes active no matter what the reason for shut-down. You can reset the fault circuit by temporarily removing power from the system. If the fault is due to over-temperature, you must allow time for the drive to cool down.

---

**Motor Stalls**

A motor stall during acceleration may be caused by one or more of the following factors:

- The torque requirements may be excessive
- The acceleration ramp may be too steep
- The load inertia and rotor inertia may be grossly mismatched.

Lower acceleration may be required.

If the motor stalls during the constant velocity portion of a move, the shaft and/or coupler may be damaged or binding due to improper coupling or excessive motor load.

A stall may occur if the DIP switch setting for the motor current selection is incorrect. The motor may not be receiving enough current to operate.

### **Motor Fails to Run at High Speeds**

If the motor fails to run at high speeds, it is possible that the motor may not produce enough torque to move a given load at these velocities. Check the torque/speed curves in the catalogue and make sure you are trying to run the motor within its range.

---

### **Motor is Jerky or Weak**

Check that there are no mechanical problems at the load causing highly variable loading condition. Disconnect the motor from the load and run it without a load connected. Try to manually turn the motor shaft; this will determine if the motor is maintaining full holding torque. Check the DIP switches (or R59 for CD 20/30/40) for proper current settings.

---

### **Motor Overheats**

If the motor exceeds its maximum motor case temperature rating, failure will eventually result. Check your DIP Switch settings to ensure that the current setting is correct for the motor you are using. For CD25, 25M, 35, and 35M drives, if your current setting is correct, change the drive DIP Switch 5 (located on the inside of the CD drive motherboard) to the OFF position, de-activating current square-off. *Note that although this will lower the motor operating temperature it will reduce mid-range torque output.*

The Standby Current feature reduces motor current by 50% when the motor is not moving. If the motor is hot after a long period at standstill (standby), check the standby current with a current probe.

---

### **Reducing Electrical Noise**

For information on identifying and suppressing electrical noise, refer to the Technical Data section of the *Digiplan Programmable Motion Control Catalogue*.

---

### **Returning the System**

If you must return your CD drive system to effect repairs or upgrades, use the following steps:

1. Get the serial number and the model number of the defective unit, and a purchase order number to cover repair costs in the event the unit is determined by the manufacturers to be out of warranty.
2. Before you return the unit, have someone from your organization with a technical understanding of the equipment and its application include answers to as many of the following questions as possible:

- What is the extent of the failure/reason for return?
  - How long did it operate?
  - Did any other items fail at the same time?
  - What was happening when the unit failed (i.e., installing the unit, cycling power, starting other equipment, etc)?
  - How was the product configured (in detail)?
  - What, if any, cables were modified and how?
  - With what equipment is the unit interfaced?
  - What was the application?
  - What was the system environment (temperature, enclosure, spacing, unit orientation, contaminants, etc.)?
  - What upgrades, if any, are required (hardware, software, user guide)?
3. In the UK, call Digiplan for a GRA (Goods Returned Authorisation) number. Returned products cannot be accepted without a GRA number. The phone number for Digiplan Repair Department is 0202 690911. For Customer Service/Applications Department phone 0202 699000.

Ship the unit to:      Parker Hannifin plc  
                                 Digiplan Division,  
                                 21, Balena Close,  
                                 Poole,  
                                 Dorset,  
                                 England.  
                                 BH17 7DX

4. In the USA, call Parker Compumotor for a Return Material Authorization (RMA) number. Returned products cannot be accepted without an RMA number. The phone number for Parker Compumotor Applications Department is (800) 358-9070.

Ship the unit to:      Parker Hannifin Corporation  
                                 Digiplan Division  
                                 5500 Business Park Drive  
                                 Rohnert Park, CA 94928  
                                 Attn: RMA # xxxxxxxx

5. Elsewhere: Contact the distributor who supplied the equipment.



---

# Index

---

- Anti-resonance, 19
- ASCII, 3
- Assumptions, v
- Automatic square-off, 19
- Auxiliary Indexer Connections, 27
- Auxiliary Indexer I/O, 36
  
- Basic electronics, v
- Basic motion control, v
  
- CC Rack, 40
- CC Series Rack Configurations, 2
- Contents of This Manual, v
- Conventions, vi
- Current Programming, 17, 24
  
- De-energize at Standstill, 24
- Dimensional Drawings, 40
- DIP switch, 16
- DIP switch setting, 45
- Drive Functions (CD20, CD30 and CD40 drives only), 23
- Drive Functions (CD25/25M and 35/35M only), 15
- Drive Maintenance, 43
- Drive resolutions, 7
  
- Edge Connections, 6
- EMI, 27
- Enclosure Considerations, 26
- Energize, 24
- Environmental Considerations, 26
- Environmental Specifications, 31
  
- Factory Default Settings, 37
- Factory Settings, 8
- Fault LEDs, 45
  
- GRA (Goods Returned Authorisation) number, 47
  
- I/O Descriptions, 35
- I/O Specifications, 35
- I/O Wiring Diagrams, 36
- Indexer Inputs, 35
- Installation Process Overview, v
- Installation Recommendations, vi
- Mode selection, 19
  
- Motherboard DIP Switch Settings, 16
- Motor Connections, 8
- Motor Fails to Move, 44
- Motor Fails to Run at High Speeds, 46
- Motor is Jerky or Weak, 46
- Motor Maintenance, 43
- Motor Outputs, 36
- Motor Overheats, 46
- Motor Stalls, 45
- MS20 DIP Switch Settings, 20
- MS20 mini-stepping card, 2
  
- National Electrical Code, 27
  
- Pinouts and connectors, 33
- Power-up, 14
- Product Description, 1
- Product Features, 2
- Profile, 20
- Proper grounding, 27
  
- Reducing Electrical Noise, 46
- Related Publications, vii
- Resistor R59, 25
- Return Material Authorization (RMA) number, 47
- Returning the System, 46
  
- Selecting Drive Resolution, 16
- Set-up procedures, 15
- Ship kit, 5
- Spare parts, 43
- Square-off, 18
- Standby current, 17, 25
- Stepping Mode (Resolution), 24
- System Connections, 26
- System Pinouts and Connectors, 33
- System Specifications, 32
  
- Theory of Operation, 3
- Transformer Connections, 12
- Transformer Mounting, 26
- Transformer Wiring, 38
- Transformers, 41
- Troubleshooting, 44
  
- Warnings (Personal Injury) & Cautions (System Damage), vii

