

PNC3 Maintenance Manual

1/ PNC3 Control Unit Information

- a) Built in diagnostics / Fault messages
- b) Preliminary Fault Finding
- c) Block diagram of control unit
- d) Basic operation of control unit
- e) Basic operation of Printed circuit boards
- f) Block diagrams of Printed circuit boards
- g) Circuit diagrams of printed circuit boards
- h) Circuit board layouts
- j) PNC3 Internal connections/wiring
- k) PNC3 PORT details
- l) Error messages

1/ a) Built in Diagnostics / Fault messages.

Each time the PNC3 stepper motor control unit is switched on the control unit carries out a self test procedure which checks the following:

- 1) System RAM (Random Access Memory)
 - 2) System EPROM (Electrically Programmable Read Only Memory)
 - 3) Keyboard is tested for short circuit Keys
- 1) The system RAM is checked in 2 stages
 - a) Stage 1 checks if the 1st 256 bytes are operating correctly if not the test continues until the power is removed. If this RAM section is OK then
 - b) Stage 2 checks the remaining 5.75K bytes. If an error is detected the faulty IC (integrated Circuit) number is displayed on the VDU (Visual Display Unit). If the RAM is OK testing proceeds.
 - 2) The system ROM is checked to ensure that all ROMs are functioning correctly. If an error is detected the program version number together with a list of ROM numbers with their actual and correct checksums is displayed. If the ROM is OK testing proceeds.
 - 3) program versions 3.14 onwards carry out a Keyboard test to ensure that there are no short circuit Keys. If a short circuit Key is found its number is shown on the VDU.

Note The RAM, ROM and Key numbers are as labelled on the Processor/Keyboard printed circuit board issue 2 onwards which is located behind the front panel.

System Fault Diagnosis (Operator checks)

A number of system checks may be carried out by the operator to check that various parts of the complete machine are functioning. The following checks can only be made prior to the machine being ZEROed:-

- 1) System EPROM checks
- 2) Keyboard tests
- 3) Input signals test
- 4) RS232 Serial Link test (to be added)

NOTE - Each test is ended by pressing the 'RESET' Key.

- 1) System EPROM can be checked by pressing the 'S' Key. The display will then show the program version number together with a list of ROM numbers with their actual and correct checksums which should always agree.
- 2) If the PNC3 stepper motor control unit is switched on whilst a Key is depressed on the keyboard the control will do a Keyboard test where the number of each Key depressed is displayed. Only one Key should be depressed at once. A faulty Key will result in either no Key number being displayed if the Key is open circuited, or the faulty Key number will always be displayed if the Key is short circuited.
- 3) The PNC3 stepper motor control unit uses many input signals some of which come from the machine being controlled. These signals are arranged as 'ports' having in general 8 bits.

The input ports used are:-

- a) PC - Datum markers, spindle speed sensors and spares
- b) PD - Machine input switch signals
- c) PE - Printer Status and control unit 'assign' switches
- d) P4A - Axis step and direction signals
- e) P4B - Axis drive fault and overtravel signals
- f) P6 - Optional additional Serial Link (not normally fitted)
- g) POR - Machine control switches and Cassette unit status

a) PC - Port C is used for the Datum Signals from each of the axes and for the spindle speed sensors (only used on programmable spindle speed systems)

bit assignments:-

	7	6	5	4	3	2	1	0
LATHES:	Spindle encoder 200/rev 1=HOLE	Spindle encoder 1/rev 1=HOLE	Z Datum 1=METAL	X Datum 1=METAL	SPARE	SPARE	SPARE	SPARE
MILL:	Spindle encoder 1/rev 1=metal	Z Datum 1=metal	Y Datum 1=metal	X Datum 1=metal	Spare	Spare	Spare	Spare

b) PD - Port D is used for the machine input switch signals

bit assignment:-

	7	6	5	4	3	2	1	0
	INPUT 7	INPUT 6	INPUT 5	INPUT 4	INPUT 3	INPUT 2	INPUT 1	INPUT 0
	0=CLOSED	0=CLOSED	0=CLOSED	0=CLOSED	0=CLOSED	0=CLOSED	0=CLOSED	0=CLOSED

c) PE - Port E is used for the printer Status signals and for the unit 'assign' switches.
IMPORTANT:- If the unit assign switches are changed they must be set back to their original settings at the end of the test or certain characteristics of the control unit will change.

bit assignment:-

	7	6	5	4	3	2	1	0
	PRINTER /ACK 0=ACK	PRINTER BUSY 1=BUSY	SWA 6 1=ON	SWA 5 1=ON	SWA 4 =ON	SWA 3 1=ON	SWA 2 1=ON	SWA 1 1=ON

d) P4A - Axis step and direction signals. These signals are used by the control unit to control the stepper motors.

bit assignments:-

	7	6	5	4	3	2	1	0
	4th axis DIR'H 1=+VE	3rd axis DIR'H 1=+VE	2nd axis DIR'H 1=+VE	1st axis DIR'H 1=+VE	4th axis STEP 1=STEP	3rd axis STEP 1=STEP	2nd axis STEP 1=STEP	1st axis STEP 1=STEP

e) P4B - Axis drive faults and overtravels. Note the axis drive fault signals are only active if the stepper motor drives are switched ON.

bit assignments:-

	7	6	5	4	3	2	1	0
	4th axis drive fault 1=OK	3rd axis drive fault 1=OK	2nd axis drive fault 1=OK	1st axis drive fault 1=OK	4th axis over/travel 1=OK	3rd axis over/travel 1=OK	2nd axis over/travel 1=OK	1st axis over/travel 1=OK

f) P6 Port 6 is used by the optional additional serial link.

g) POR - Port 0 Read is used for the Machine Control switches and for the digital cassette status signals.

	7	6	5	4	3	2	1	0
	Machine STOP 1=stop	AUTO/MANUAL 0=AUTO	START 0=START	Cass clear leader 1=CLR LDR	Cass Data 0=DATA	Cass present 0=CASS pres	Cass File protect 1=FILE Protect	Machine Single step 0=SINGLE STEP

1/b) Preliminary Fault Finding

The following symptoms of basic problems with the control unit are included as a fault finding aid. Before attempting to resolve more complex problems the user should become familiar with information in the maintenance manual.

NOTE System power must always be removed from the control unit before removing/disconnecting or replacing any components/connectors etc. The control unit may be operated if necessary with the outer cover removed but great care must be taken as dangerous high voltages are then exposed.

SYMPTOM	CHECK	NORMAL	ABNORMAL
1/Unit fails to function when switched ON	a) Main Power ON b) ON switch on unit rear is ON c) Fuse F1 on unit d) Power OK indicator on front panel	ON i.e. power is present If no display after 2 mins remove power, remove control unit cover and check internal connections	OFF Wait for 2 minutes a) if no display remove power, remove control unit cover and check all internal connections. b) If display comes on replace ON indicator
	e) Check 3 green DC power indicators on power distribution board.	all ON go to 1K)	one or more off. Check relevant fuses on power distribution board.
	f) Remove interface board and PLD on power distribution	all 3 green indicators ON	one or more off - Replace Power Distribution board
	g) Replace PLD on power distribution board	all 3 green indicators ON	if +12v indicator off Replace VDU driver board at L.H.S. of unit.
	h) Replace Interface board and remove PLD on interface board	all 3 green indicators ON	if +5v OR 12VI indicator off. Replace interface board.

SYMPTOM

CHECK

NORMAL

ABNORMAL

j) Replace PLD

all 3 green indicators ON

+5v indicator OFF - Replace Processor/Keyboard

k) Ensure PRORAME switch set to MANUAL. Depress Green On switch above STOP switch.

Stepper Motors should 'energise'

Stepper Motors do not energise
goto m

l) Press 'ZERO' Key

Machine moves towards Zero. Press PROC STOP Key. Check wiring to VDU. Replace VDU driver board at L.H.S of unit. Replace PNC3-VDU board.

go to l
Nothing happens - replace processor board.

m) Check green indicators at lower L.H.S. of unit

all On
Remove power
Check Motor connections X,Y,Z as applicable at rear of drive on PCB

one only off - Check relevant fuse on PCB on rear of drives. All off - proceed

n) check 2 green supply indicators on PCB at rear of drives

both on

one or more off - check fuses on PCB. and supply

p) check Red indicators on Drives

all OFF

one or more ON - consult Drive handbook Section 5

Unit Displays
RAM ERROR
when switched
ON

Remove Outer cover and front panel and replace Processor/Keyboard

SYMPTOM	CHECK	NORMAL	ABNORMAL
Unit Displays XX Keypressed when switched OK	Remove Outer cover and front panel and replace respective Key on Processor/Keyboard OR replace Processor/Keyboard.		
Machine fails to move when 'ZERO' pressed	Does display change when ZERO is first pressed to 'machine moving to datum'	YES Remove outer cover, check all connections, go to L.	Display does not change proceed, OR if error message displayed see error messages. -----
	Ensure display indicates Manual Mode	HDI shown at top Right of VDU. Carryout Keyboard test - see Built in diagnostics. If OK replace processor/keyboard.	HDI not shown - check setting of PROGRAMME switch should be set to MANUAL. Replace switch. -----
MACHINE moves when ZERO is pressed but runs into a machine limit before datum is reached	Press PROG.STOP. Carryout checks detailed in system diagnostics by operating respective overtravel switches (if fitted) and by placing a ferrous object over each datum detector in turn.	All relevant port signals should change as indicated in system diagnostics	Any abnormal- ities should be corrected by a) checking the system wiring b) Replacing the defective component
OTHER FAULTS	Please obtain as much relevant information about the faults as possible and obtain ROM checksums (see 1/ a)? before contacting the supplier.		
Unit Displays 'ROM ERROR' when switched OK	Remove Outer cover and front panel of unit ensure all integrated circuits are 'plugged in' correctly. If fault persists, replace EPROMS. If fault persists Replace Processor/Keyboard.		

1.d) Basic Operation of Control Unit

The PMC3 Control Unit consists of a number of elements housed in a purpose built cabinet. The elements are shown in the Block diagram of the control unit.

Main power either at 220/240vac 50/60hz or at 110/120vac 50/60hz single phase is fed to the power distribution board then via the rear panel mounted 'ON' switch and fuse to the power supply components which generate DC power for the system.

If the rear panel switch is ON power is supplied via the logic transformer to the +5, +12, 12VI and -8 volt supplies which power the computer section and the VDU.

The +5 +12 and 12VI supplies each have an indicator and a fuse. The +5, 12VI and -8volt supplies supply the computer section. The 12volt supply supplies the VDU unit.

The computer section comprises the interface board, the processor/keyboard, the PMC3 VDU board, the cassette unit and the programme control switches.

The processor/keyboard consists of a 8 bit microprocessor, associated EPROM and RAM together with control logic, and a 61 character keyboard. The processor/keyboard controls all functions and characteristics of the control unit enabling programmes defining the components to be produced to be loaded into its memory then edited/stored as desired and executed sequentially one instruction at a time as required. The processor/keyboard also provides all messages to be displayed on the integral VDU which is driven by the VDU drive board via the PMC3 VDU board. The PMC3 VDU board generates the display on the VDU and the display is updated/changed as required by the processor/keyboard.

The interface board contains all the PORTS, up to 4 axes of control electronics, up to 8 input switch monitoring, datum detector monitors, a single analogue output channel, an optional additional RS232 serial port, and a parallel printer port. Optical isolators are fitted to all machine input and output signals to minimize any adverse effects from electrical interference.

Power to the stepper motor drive system is supplied via the front panel mounted STOP and ON switches, to the drive transformer. The drive transformer and associated components provides +24volts and +55volts DC to power the drive units which in turn power the stepper motors. The drives are high performance bipolar chopper types, CD20 models generally being fitted. The drives have internal protection and fault monitoring circuiting. (For more details consult the DIGIPLAN CD20 instruction manual).

The control system is connected to the machine by the system connections which are generally made through the centre of the machine arm upon which the control unit is mounted.

1/ e) Basic Operation of printed circuit boards.

Power Distribution Board.

The power distribution board contains the latching drives mains relay, the logic power mains filter, the +12volt, +5volt, +12volt isolated and -8volt supplies.

Single phase 110-120vac or 220-240vac 50/60hz is supplied to the PNC3 control unit via the switch and mains fuse F1 mounted on the rear panel. Main power is then taken to the front panel mounted STOP switch, ON switch and ON indicator and also to the mains filter which filters the mains supply to the logic transformer powers supplies.

The logic transformer supplies power for the following supplies:-

- a) The +12volt 2 amp supply which powers the VDU drive board and CRT.
- b) The +5volt 2.5amp supply which powers the interface, PNC3 VDU and Processor/keyboard printed circuit boards.
- c) The 12 volts 1 amp isolated supply which powers optial isolators for the overtravel switches, the input switches, machine datum detectors and relays and also the relay drives.
- d) The low current -8volt supply which is used as a negative supply for the RS232 serial link.

Note: Three green indicators on supplies a),b), and c) indicate if the supply is ON.

The latching mains relay latches the stepper motor drive system mains power after the ON switch on the front panel is pressed. The front panel power ON indicator is powered via a diode D1 and resistor R1 from a 110vac supply from the logic transformer.

Interface Board.

The interface board contains the axis movement control electronics, overtravel and stepper motor drive fault monitoring electronics, spindle speed control logic (consisting of an analogue voltage), an RS232 port, auxilliary relays, datum detector monitoring, input switch monitoring, printer control and assign switches.

The numerous facilities of the control unit are arranged as a series of ports. The ports used are:-

Port	Function
0	Kii3701 Continuous Path Controller
2	Programmable timer 1
3	Programmable timer 2
4A	Axis step/direction monitoring signals
4B	Axis overtravel and drive fault signals
4C	Axis acknowledge signals and reset signals
4D	Axis boost and direction control signals
5	Enables the auxiliary and spindle speed control functions to operate
6	Optional RS232 link
7	Extension board 1 (option)
8	Auxiliary 1-8 control
9	Auxiliary 9-16 control
A	Spindle speed control (Analogue output)
B	Printer Data
C	Datum Detector and spare monitor signals
D	Input switch monitor signals
E	Unit assign switch and printer status signals
F	Extension board 2 (option)

A complete list of the port signals is included at 1/ k).

All machine control and monitoring signals are fed via optical isolators thus breaking any direct electrical link between the machine and control unit.

Control of the XY axes is provided by the programmable timers (which control movement speed) and the Kii3701 2 axes continuous path controller (which controls the XY axis movement direction).

The Z and 4th axis controller is provided using the programmable timers. Movement of any axis is inhibited if that axis has an overtravel condition in the direction in which movement is attempted or if that axis has a drive fault. Movement pulses produced by the Kii3701 are "smoothed" by IC30 which is generally used as a divide by 4 element (dependant on board linking). IC's 15 and 17 are used to provide a movement pulse of approx 25 micro-secs to be compatible with the stepper motor drive unit.

VR1 and VR2 (if fitted) set the maximum speed of movements.

Axis movement is monitored by the control unit enabling the precise position of the machine to be found. Each movement step together with its direction is monitored by the processor via PORTS 4A and 4C. Port 4D is used to control the movement direction of the Z and 4th axis and also sets the axis 'boosts' which are generally used to increase the power fed by the stepper motor drive to the stepper motor during motor accelerations.

Axis overtravel signals provided by optional machine mounted switches are fed via optical isolators to the axis overtravel logic which monitors the overtravel switches dependant on the direction of machine movement required. The resultant signals are used to enable/disable the output step signals to the relevant axes and the signals are also taken to port 4D.

The stepper motor drives fitted provide a fault signal if a drive/motor fault is detected. The fault signals are fed via optical isolators to also enable/disable the output step signals to the relevant axes and to PORT 4D enabling the processor to monitor the signals.

The data bus buffering/control and port decoding provide the necessary signals to enable the other components on the interface board to function correctly.

The spindle speed control is accomplished by PORT A, optical isolators IC59 to IC62, IC64 a low power digital to analogue convertor and IC's 63, 65 low power op-amps. IC's 59 to 65 are powered by the supply provided by the spindle speed control unit which is external to the PNC3 controller, a 10 to 12v DC supply of typically 2milliamps being required. VR3 enables the output signal on PLH pin 3 to be set. (This control is factory set to provide the required maximum speed when the control is demanding maximum speed.)

The optional additional RS232 Serial Link uses an 8251 Serial Controller.

Ports 8 and 9 are used to control relays via optical isolators and high current relay driver circuits. Relays 1 to 10 and 14 to 15 are conventional relays capable of switching 1amp. Relays 11 to 13 are Solid State Relays which can switching only AC current up to 1 amp and are ideally switched to switching power to inductive loads because these relays are zero voltage switches.

Both the spindle speed control and auxiliary control have the added protection of only functioning if the processor has accessed Port 5 after initial power up. At power up IC1 pt2 is reset removing the output enable from PORTS 8,9 and A thus disabling them. The outputs are enabled when the processor accesses PORT 5 and sets IC1 driving the o/p ON signal low.

Datum detector signals are derived from a proximity detector equivalent to the TURCK Bi 1 G08 Y0. The proximity detectors are the inductive type. When no metal is detected the detector stops oscillating and acts as a high resistance. When metal is detected the detector acts as a low resistance. The detectors are powered by approx 8volts from the PNC3 control unit.

Signals from the detectors are fed via transistor amplifiers then via optical isolators to PORT D.

Printer data is fed via PORT B to the printer connector on the rear of the control unit. The printer strobe signal is produced by PORT 4D bit 4. Printer status is monitored by PORT E which is connected to the printer BUSY and ACK signals. PORT E is also used by the 6 control assign switches which are used to select certain facilities of the control unit.

processor / Keyboard.

The Processor/keyboard controls all PNC functions i.e. data input and display, machine status monitoring and display, machine positioning/control and cassette unit control.

At the heart of the processor board is an 8085 8 bit microprocessor. The microprocessor sequentially obeys instructions contained in the Electrically Programmable Read Only Memory (EPROM). These instructions which are put into the EPROM's during manufacture are stored in a coded form. The instructions characterize and control all of the operations which the control unit is capable of.

Random Access Memory (RAM) is read/write memory, this is used to store both data required by the EPROM programme and also positioning, spindle control, auxilliary and input section information.

The cassette control ports control the storage and retrieval of data to/from the integral digital cassette unit.

The programme control switch port enables the settings of the programme control switches to be monitored.

The processor/keyboard also includes a 61 character keyboard which is monitored by the 8085 microprocessor via the keyboard ports. The keyboard is multiplexed by the output port P2W and keypressed data is read by the input port P1R.

The 8085 microprocessor communicates with the PNC3 VDU board via connector C and with the INTERFACE board via connector D.

All control signals, address, data and restart signals are buffered.

Basic Operation of PNC3 VDU Board

The PNC3 VDU board generates the composite video signals to produce the VDU display.

The PNC3 VDU board consists of address, control and data bus buffers/decoders, a character generator/data interface, page memory, extended character generator memory and buffer decoders, a video interface and display clock, and a video driver.

Characters to be displayed together with their attributes e.g. reverse video, are stored in page memory which stores 25 rows of 40 characters. The memory is arranged to be 1K x 16 bits. The video display is generated by the display clock and video interface which accesses sequential locations of page memory to determine which character is to be displayed together with its attributes. Data determining the formation of each character is obtained by the video interface either from the character generator or from the extended character generator memory dependant upon a character definition attribute bit.

Characters to be displayed are stored in page memory into their correct display position by the Processor/Keyboard via the buffers/decoders and the data interface. These characters may be read by the processor/keyboard using the same components.

The video driver combines the full intensity and half intensity signals with the picture sync signals to produce 1v composite video on two output lines one of which is connected to the VDU driver board and the other to the extension video socket on the rear of the control unit.

1/ j) PNC3 Internal Connections

PROCESSOR BOARD CONNECTORS

PLA - PROGRAM CONTROL SWITCHES

PIN	SIGNAL
1	/SINGLE STEP
2	/START
3	MAN/AUTO
4	/STOP
5	0VOLTS

SKE - CASSETTE UNIT SIGNALS

PIN	SIGNAL
1	POLARISING
4	DATA TO CASSETTE
5	/CASS PRESS
6	WR/RD
7	/FILE PROTECT
8	+5V
9	0V
10	EARTH
11	RWD/FWD
12	SL/FST
13	DATA FROM CASSETTE
14	CL LDR
15	STOP/CO
16	+5V

PROCESSOR BOARD CONNECTORS

CONNECTOR C - PNC3 VDU BOARD CONNECTOR

PIN	ROW A (RH)	SIGNALS	Row C (LH)
1	+5V	ROW B	+5V
2	SPARE	+5V	RDY
3	HOLD	SPARE	SPARE
4	RSTOUT	/WR	CLK
5	IO/E	/INTA	/RD
6	HOLDA	ALE	D7
7	D6	D5	D4
8	D3	D2	D1
9	D0	A15	A15
10	A14	A13	A13
11	A12	A11	A11
12	A10	A9	A9
13	A8	A0	A1
14	A2	A3	A4
15	A5	A6	A7
16	0V	0V	0V

PROCESSOR BOARD CONNECTORS

CONNECTOR D

PIN	SIGNAL	PIN	SIGNAL
	LHROW		
1	+5V	26	+5V
2	SER IN	27	SER OUT
3	RST 7.5	28	RST 6.5
4	RST 5.5	29	INTR
5	SPARE	30	SPARE
6	SPARE	31	SPARE
7	RDY	32	HOLD
8	SPARE	33	SPARE
9	RST OUT	34	/WR
10	CLK	35	IO/H
11	/INTA	36	/RD
12	HOLD A	37	ALE
13	D7	38	D6
14	D5	39	D4
15	D3	40	D2
16	D1	41	D0
17	A15	42	A14
18	A13	43	A12
19	A11	44	A10
20	A9	45	A8
21	A0	46	A1
22	A2	47	A3
23	A4	48	A5
24	A6	49	A7
25	OV	50	CV

INTERFACE BOARD CONNECTORS

SKA - EXTENSION BOARD 1	
PIN	SIGNAL
1	+5V
2	DB7
3	DB6
4	DB5
5	DB4
6	DB3
7	DB2
8	DB1
9	DB0
10	/P7
11	/WR
12	/RD
13	A9
14	A8
15	SPARE
16	OV

SKB - AXIS ONVERTTRAVEL SIGNALS	
PIN	SIGNAL
1	OVI
2	-XOT
3	+XOT
4	-YOT
5	+YOT
6	POLARISING
7	-ZOT
8	+ZOT
9	-WOT
10	+WOT

INTERFACE BOARD CONNECTORS

PLC - STEPPER MOTOR DRIVE SIGNALS

PIN	SIGNAL
1	OV DRIVE
2	+24V DRIVE
3	X DRIVE FAULT
4	X BOOST
5	X DIRN
6	X STEP
7	OV DRIVE
8	
9	Z DRIVE FAULT
10	Z BOOST
11	Z DIRN
12	Z STEP
13	
14	OV DRIVES
15	+24V DRIVE
16	Y DRIVE FAULT
17	Y BOOST
18	Y DIRN
19	Y STEP
20	OV DRIVE
21	
22	T DRIVE FAULT
23	T BOOST
24	T DIRN
25	T STEP
26	

PLD - SEE PROCESSOR BOARD CONNECTORS - CONNECTOR D

INTERFACE BOARD CONNECTORS

SKE - DC POWER SUPPLIES

PIN	SIGNAL
1	12VI
2	12VI
3	0VI
4	0VI
5	-8V
6	
7	
8	
9	+5V
10	+5V
11	+5V
12	+5V
13	0V
14	0V
15	0V
16	0V

PLF -- OPTIONAL ADDITIONAL (RS232 LINK)

PIN	SIGNAL
1	-
2	/TXD
3	/RXD
4	RTS
5	CTS
6	DSR
7	OV
20	DTR

INTERFACE BOARD CONNECTORS

PLG - AUXILLIARY FUNCTION CONNECTIONS

PIN	SIGNAL	
1	AUX 10	H/O
2	AUX 9	H/O
3	AUX 2	H/O
4	AUX 1	H/O
5	AUX 11-14	COMMON *
6	AUX 9,10	COMMON
7	AUX 1-4	COMMON
8	AUX 3	H/C
9	AUX 12	H/O
10	AUX 11	H/C
11	AUX 3	H/O
12	AUX 4	H/O
13	AUX 14	H/O *
14	AUX 13	H/O *
15	AUX 6	H/O
16	AUX 5	H/O
17	AUX 16	H/C
18	AUX 15,16	COMMON
19	AUX 5,6	COMMON X
20	AUX 6	H/C
21	AUX 16	H/O X
22	AUX 15	H/O
23	AUX 8	H/O
24	AUX 7	H/O

* These auxilliaries are SOLID STATE RELAYS suitable for 110-240vac only

X LINKS may be made a PCB changing the function of these pins

PLH - ANALOGUE OUTPUT (Normally Spindle Control)

PIN	SIGNAL
1(LH)	10 - 12V DC
2	-
3	ANALOGUE OUT
4	-
5(RH)	0V DC

SKJ - Extension Board Connector
As SKA but pin 10 is /PF

SKK - INPUT SWITCH SIGNALS	
PIN	SIGNAL
1	OVI
2	POLARISING
3	INPUT 0
4	INPUT 1
5	INPUT 2
6	INPUT 3
7	INPUT 4
8	INPUT 5
9	INPUT 6
10	INPUT 7

PLL - SPARE SIGNALS	
PIN	SIGNAL
2	OVI
2	-
3	-
4	SPARE 0
5	SPARE 1
6	SPARE 2
7	SPARE 3
8	-

INTERFACE BOARD CONNECTORS

SK11 - RS232 LINK

PIN	SIGNAL
2	0VOLTS
6	SERIAL DATA FROM PNC3
7	SERIAL DATA TO PNC3

PLN - DATUM DETECTOR SIGNALS

PIN	SIGNAL
1	8VI
2	SPARE INPUT
3	X AXIS DATUM
4	Y AXIS DATUM
5	Z AXIS DATUM
6	T AXIS DATUM

PLP - PRINTER SIGNALS

PIN	SIGNAL
1	DATA STROBE
2	DATA 0
3	DATA 1
4	DATA 2
5	DATA 3
6	DATA 4
7	DATA 5
8	DATA 6
9	DATA 7
10	/ACK
11	BUSY
14-25	0 VOLTS

1/ k) PNC3 PORT DETAILS

Processor/Keyboard Ports

<u>PVDU</u>	Addr C0 - C4	VDU Controller I/O
<u>POI</u>	Addr D8	I/P Cassette status, PROGRAMME switches
Bit Allocation:-		
7 /STOP	6 /AUTO	5 /START
		4 CLR.LDR
		3 DATA IN (FROMCASS)
		2 CASS. PRES.
		1 FILE PROTECT
		0 /S.STEP
<u>POU</u>	Addr D8	O/P Cass. Control
Bit Alloc:-		
7 Spare	6 Exthem ACC	5 Spare
		4 DataOut (ToCass)
		3 Slow Fast
		2 Rewind Forward
		1 WR RD
		0 Stop Go
<u>P1R</u>	Addr D9	Keyboard Inputs (row signals)
<u>P2W</u>	Addr DA	Keyboard Output Digit Selects

Interface Board Ports

<u>P01</u>	Addr A0 - A7	KM3701 I/O (Note Kireset is on P4C bit 6)
<u>P2</u>	Addr A8 - AB	Range Timer (I/O)
<u>P3</u>	Addr AC - AF	Feed Timer (I/O)
<u>P4A</u>	Addr B0	Step and Dirn I/P's
Bit Allocation:-		
7 Tdir ⁿ /n	6 Zdir ⁿ /n	5 Ydir ⁿ /n
		4 Xdir ⁿ /n
		3 Tstepin
		2 Zstepin
		1 Ystepin
		0 Xstepin
<u>P4B</u>	Addr B1	Overtravels and Drivefaults
Bit Allocation:- -VE LOGIC		
7 /Tdrive fault	6 /ZDF	5 /YDF
		4 /XDF
		3 /Tover travel
		2 /ZOT
		1 /YOT
		0 /XOT
<u>P4C</u>	Addr B2	Axes ACK, KMRESET, CLK Select (O/P's)
Bit Allocation:-		
7 CLKSEL	6 KMRES	5 Spare
		4 Spare
		3 TACK
		2 ZACK
		1 YACK
		0 XACK
<u>P4D</u>	Addr B3	Axes BOOSTS, Z & T DIRNS, Printer Strobe (O/P's)
Bit Allocation:0		
7 Tdirn	6 Zdirn	5
		4 Printer Strobe
		3 /Tboost
		2 /Zboost
		1 /Yboost
		0 /Xboost

P5 Addr B4 Latch to initiallise Ports 8,9,A

P6 Addr B8 - B9 8251A Serial Port (I/O)

P7 Addr BC - BF 1st (Upper) Extension Board

P8 Addr 80 O/ Auxilliarys 0 - 7

Bit Allocation:- -VE LOGIC

7	6	5	4	3	2	1	0
AUX7	AUX6	AUX5	AUX4	AUX3	AUX2	AUX1	AUX0

P9 ADDR 84 O/P Auxilliarys 8 - 15

Bit Allocation:- -VE LOGIC

7	6	5	4	3	2	1	0
AUX15	AUX14	AUX13	AUX12	AUX11	AUX10	AUX9	AUX8

PA Addr 88 O/P Spindle Speed

Bit Allocation:- -VE LOGIC

7	6	5	4	3	2	1	0
MSB							LSB

PB Addr 8C O/P Data to printer

Bit Allocation:-

7	6	5	4	3	2	1	0
DATA7	DATA6	DATA5	DATA4	DATA3	DATA2	DATA1	DATA0

PC Addr 90 I/P Machine datums and spare inputs

Bit Allocation:-

7	6	5	4	3	2	1	0
TKKR	ZIKR	YIKR	XIKR	SPARE	SPARE	SPARE	SPARE

PD Addr 94 I/P Switches

Bit Allocation:- -VE

7	6	5	4	3	2	1	0
I/P7	I/P6	I/P5	I/P4	I/P3	I/P2	I/P1	I/P0

PE Addr 98 I/P Printer Status, Assign Switches

7	6	5	4	3	2	1	0
PRINTER /ACK	PRINTER BUSY	SWA6	SWA5	SWA4	SWA3	SWA2	SWA1

PF Addr 9C - 9F 2nd (Lower) Extension Board

2/ a) Built in machine diagnostics.

The Control Unit has a built in machine diagnostic program which enables the maintenance engineer to test all machine mounted switches and detectors together with their associated wiring.

All signals to and from the control unit are organised into ports each of which is generally 8 bits wide.

Signals received by the control unit may be checked by:-

- a) Removing power from the control unit
- b) Switching the control unit ON
- c) Setting the programme switch to MANUAL
- d) Depressing the T (Test) Key
- e) At this point all signals necessary for the correct operation of the control unit are displayed in a 'port map'. Each of the ports together with the function of each of the bits is detailed in section 1,a,3.

2/ k) PNC3 Auxilliary Board Information.

The PNC3 Ancilliary board is a printed circuit board which may be mounted in single phase powered systems and contains compenents associated with the mains supply.

Connector Details:-

- 1) SKA connects to the mains connector C01 from PNC3 pins 1 to 11.
- 2) 12 way connector block TB1 signals:-

pin	1,2,3 - Earth, live and neutral (220v-240v AC)
	4 - Earth
	5 - 0v (24vac supply)
	6 - 24vac if PNC3 is on
	7 - Earth
	8 - LUBA
	9 - LUEB
	10 - Earth
	11 - CLNTA
	12 - CLNTB

Notes

LUBA and LUEB signals may be used in 2 ways

- a) For single phase lubricantion system (if option is fitted) LUB relay R3 is fitted and this relay switches the live (via the LUB fuse) and the neutral to LUBA and LUEB terminals respectively. S1 and LUB FUSE are fitted.
- b) For 3 phase lubrication systems (if option is fitted) LUE relay R3 is not fitted and links are fitted i.e. pin 3 is linked to 4 and pin 7 is linked to 8. LUB fuse is not fitted suppressor S1 is fitted (pins of relay base are counted clockwise from pin 1).

CLNT A are CLNT B signals:- above comments apply except that the coolant relay is R2, suppressor is S2 and fuse is labelled CLNT.

PLB This plug connects to the 24v transformer.

TB2 This terminal block provides signals for the low volt lamp.

L1 Indicates if 24vac is ON.

2/ d) PNC3 - Fasimill 3 machine wiring loom (Programmable & 2 speed spindle systems)

Connector C01 - Mains power & Motor signals

24 way QM socket from MILL

Cable	Pin	Signal	Destination	Length
Y/GN 24/.2	1	EARTH	Cont panel conn A1	102"
BN 24/.2	2	LIVE IN	Cont panel conn A2	102"
Be 24/.2	3	NEUTRAL IN	Cont panel conn A3	102"
W/R	4	LIVE OUT	Cont panel conn A4	102"
W/Bk	5	NEUTRAL OUT	Cont panel conn A5	102"
W	6	CLNT/LUB Relay Com	Cont panel conn A6	83"
	7			
	8			
	9	SPARE		
P	10	CLNT RLY N/O(A8)	Cont panel conn A10	83"
	11	LUB RLY N/O (OPTION)	Cont panel conn A11	
	12			
Bn	13	X MOTOR ph 2A	X MOTOR Terminal block	129"
R	14	X MOTOR ph 2B	X MOTOR Terminal block	129"
O	15	X MOTOR ph 1B	X MOTOR Terminal block	129"
Y	16	X MOTOR ph 1A	X MOTOR Terminal block	129"
Gn	17	Y MOTOR ph 2A	Y MOTOR Terminal block	97"
Be	18	Y MOTOR ph 2B	Y MOTOR Terminal block	97"
V	19	Y MOTOR ph 1B	Y MOTOR Terminal block	97"
Gy	20	Y MOTOR ph 1A	Y MOTOR Terminal block	97"
R/Bk	21	Z MOTOR ph 2A	Z MOTOR Terminal block	108"
R/Bn	22	Z MOTOR ph 2B	Z MOTOR Terminal block	108"
O/Bk	23	Z MOTOR ph 1B	Z MOTOR Terminal block	108"
O/Rd	24	Z MOTOR ph 1A	Z MOTOR Terminal block	108"

All wires 16/0. unless stated.

PNC 3 Auxilliary relay assignment.

Easimill High/Low

RL1}
RL2} Available to the user via rear connectors
RL3}
RL4}

RL5 Spindle "low speed" relay
RL6 Spindle "high speed" relay
RL7 Not available
RL8 Coolant relay

Easimill Program

RL1}
RL2} Available to the user via rear connectors
RL3}
RL4}

RL5 Spindle "start" relay (Parajust system only)
RL6 Spindle "run" relay
RL7 Spindle "reverse" relay
RL8 Coolant relay

Connector C02 - 2 Speed spindle control, overtravels, datum switches

24 way QM Plug from Mill

Cable	Pin	Signal	Destination	Length
R/Bk	1	SPINDLE CONT COM	Cont panel	83"
	2	---		
	3	---		
R/Bn	4	SPINDLE HI RELAY	Cont panel	83"
R/Be	5	SPINDLE LO RELAY	Cont panel	83"
	6	---		
	7	---		
	8	---		
	9	---		
Gn 12 CORE)				108"
Gn 6 CORE)	10	Overtravel switch comm	Terminal blocks	97"
R 12 CORE	11	-X O/T N/C	Terminal block	97"
O 12 CORE	12	+X O/T N/C	Terminal block	97"
Y 12 CORE	13	-Y O/T N/C	Terminal block	97"
Be 12 CORE	14	+Y O/T N/C	Terminal block	97"
R 6 CORE	15	-Z O/T N/C	Terminal block	108"
Be 6 CORE	16	+Z O/T N/C	Terminal block	108"
	17			
	18			
Bk 12 CORE)				
Bk 6 CORE)	19	Datum Detectors +	Terminal blocks	
	20			
V 12 CORE	21	X Datum Detector -	Terminal block	97"
Gy 12 CORE	22	Y Datum Detector -	Terminal block	97"
Y 6 CORE	23	Z Datum Detector -	Terminal block	108"
	24			

All cables 16/.2

12 Core Rilgained with Y motor leads
6 Core Rilgained with Z motor leads

PNC3 - Eastmill 3 machine wiring loom (Programmable spindle speed)

Connector C02 Programmable Spindle Control, overtravels, Datum switches

24 way QM Plug from Mill

Cable	Pin	Signal	Destination	Length
Bn & cable outer	1	Parajust common	Parajust TB1-1	83"
R	2	speed output	Parajust TB1-2	83"
O	3	+10v	Parajust TB1-3	83"
Y	4	START/STOP COMMON	Parajust TB1-5	83"
Gn	5	STOP	TB1-6	83"
	6			
	7			
Gy	8	SPINDLE REVERSE COMMON	Parajust TB12-1	83"
W	9	SPINDLE REVERSE N/O	Parajust TB12-2	83"
Gn (12&6 core)	10	Overtravel switch common	overtravel switch commons	108"
R (12 core)	11	-X O/T N/C	-X overtravel switch N/C	97"
O (12 core)	12	+X O/T N/C	+X overtravel switch N/C	97"
Y (12 core)	13	-Y O/T N/C	-Y overtravel switch N/C	97"
Bu (12 core)	14	+Y O/T N/C	+Y overtravel switch N/C	97"
Rd (6 core)	15	-Z O/T N/C	-Z overtravel switch N/C	108"
Bu (6 core)	16	+Z O/T N/C	+Z overtravel switch N/C	108"
-	17	---		
-	18	---		
Bk (12 & 6 core)	19	Datum detector +	Detector commons +	
-	20	---		
V (12 core)	21	X Datum detector -	X datum detector -	97"
Gy (12 core)	22	Y Datum detector -	Y datum detector -	97"
Y (6 core)	23	Z Datum detector -	Z datum detector -	108"
W (6 core)	24	SPINDLE RPM detector -	Spindle RPM detector-	108"

Combivert Mill Option.

Gn	1	Combivert Ov		83"
Rd	2	Speed Output		83"
Y	3	+10v Combivert		83"
4 TO 6 NOT USED				
GY	7	Combivert Forward (F)		83"
Wh	8	Combivert Common (ST)		83"
Bk	9	Combivert Reverse (R)		83"

All cables 16/0.2

Connector C01 internal wiring Mains pwr & Motor signals (For 2 SPEED and Programmable SPEED systems.)

24 way QM socket from MILL, PLUG from PNC

Cable	Pin	Signal	Source	Destination
Y/Gn 24/.2	1	EARTH	PDB-A1	Cnt Pnl A1
Bn 24/.2	2	LIVE 220/240v Ac	PDB-A2	" A2
Be 24/.2	3	NEUTRAL	PDB-A3	" A3
W/R 16/.2	4	LIVE OUT	PDB-L	" A4
W/Bk 16/.2	5	NEUTRAL OUT	PDB-N	" A5
Bk 16/.2	6	LUB & CLNT RLY COM	IB-G21	" A6
Gn/Rd 16/.2	7			
Gy/Be 16/.2	8			
	9	SPARE		
P 16/.2	10	CLNT RLY N/O (AUX 8 N/O)	IB-G23	" A10
Gy/Be 16/.2	11	LUB RLY N/O (OPTION)		" A11
Rd/Be 16/.2	12			
Bn 16/.2	13	X MOTOR ph 2A	X1 (DRIVE BOARD)	X MOTOR
R 16/.2	14	X MOTOR ph 2B	X2	X MOTOR
O 16/.2	15	X MOTOR ph 1B	X3	X MOTOR
Y 16/.2	16	X MOTOR ph 1A	X4	X MOTOR
Gn 16/.2	17	Y MOTOR ph 2A	Y1	Y MOTOR
Be 16/.2	18	Y MOTOR ph 2B	Y2	Y MOTOR
V 16/.2	19	Y MOTOR ph 1B	Y3	Y MOTOR
Gy 16/.2	20	Y MOTOR ph 1A	Y4	Y MOTOR
Rd/Bk 16/.2	21	Z MOTOR ph 2A	Z1	Z MOTOR
Rd/Bn 16/.2	22	Z MOTOR ph 2B	Z2	Z MOTOR
O/Bk 16/.2	23	Z MOTOR ph 1B	Z3	Z MOTOR
O/Rd 16/.2	24	Z MOTOR ph 1A	Z4	Z MOTOR

Connector C02 2 SPEED Spindle Control, overtravels, Datum switches

24 way QM plug from MILL, socket from PNC 3

Cable	Pin	Signal	Source	Destination
R/Bk 16/.2	1	SPINDLE CONT COM (24vac)	IB-G19	24vac Supply
	2	---		
	3	---		
R/Bn 16/.2	4	SPINDLE HI RLY	IB-G15	Spdl hi rly
R/be 16/.2	5	SPINDLE LO RLY	IB-G16	Spdl lo rly
	6	---		
	7	---		
	8	---		
	9	---		
Bn 16/.2	10	Overtravel switch common	IB-B1	overtravel switch commons
R 16/.2	11	-X O/T N/C	IB-B2	-X overtravel switch N/C
O 16/.2	12	+X O/T N/C	IB-B3	+X overtravel switch N/C
Y 16/.2	13	-Y O/T N/C	IB-B4	-Y overtravel switch N/C
Gn 16/.2	14	+Y O/T N/C	IB-B5	+Y overtravel switch N/C
V 16/.2	15	-Z O/T N/C	IB-B7	-Z overtravel switch N/C
Gy 16/.2	16	+Z O/T N/C	IB-B8	+Z overtravel switch N/C
	17	---		
	18	---		
R 16/.2	19	Datum detector +	IB-N1	Detector commons +
	20	---		
Y 16/.2	21	X Datum detector -	IB-N3	X datum detector -
Gn 16/.2	22	Y Datum detector -	IB-N4	Y datum detector -
Be 16/.2	23	Z Datum detector -	IB-N5	Z datum detector -
	24	---		

BLOCK DIAGRAM OF PNC 3 CONTROL UNIT.

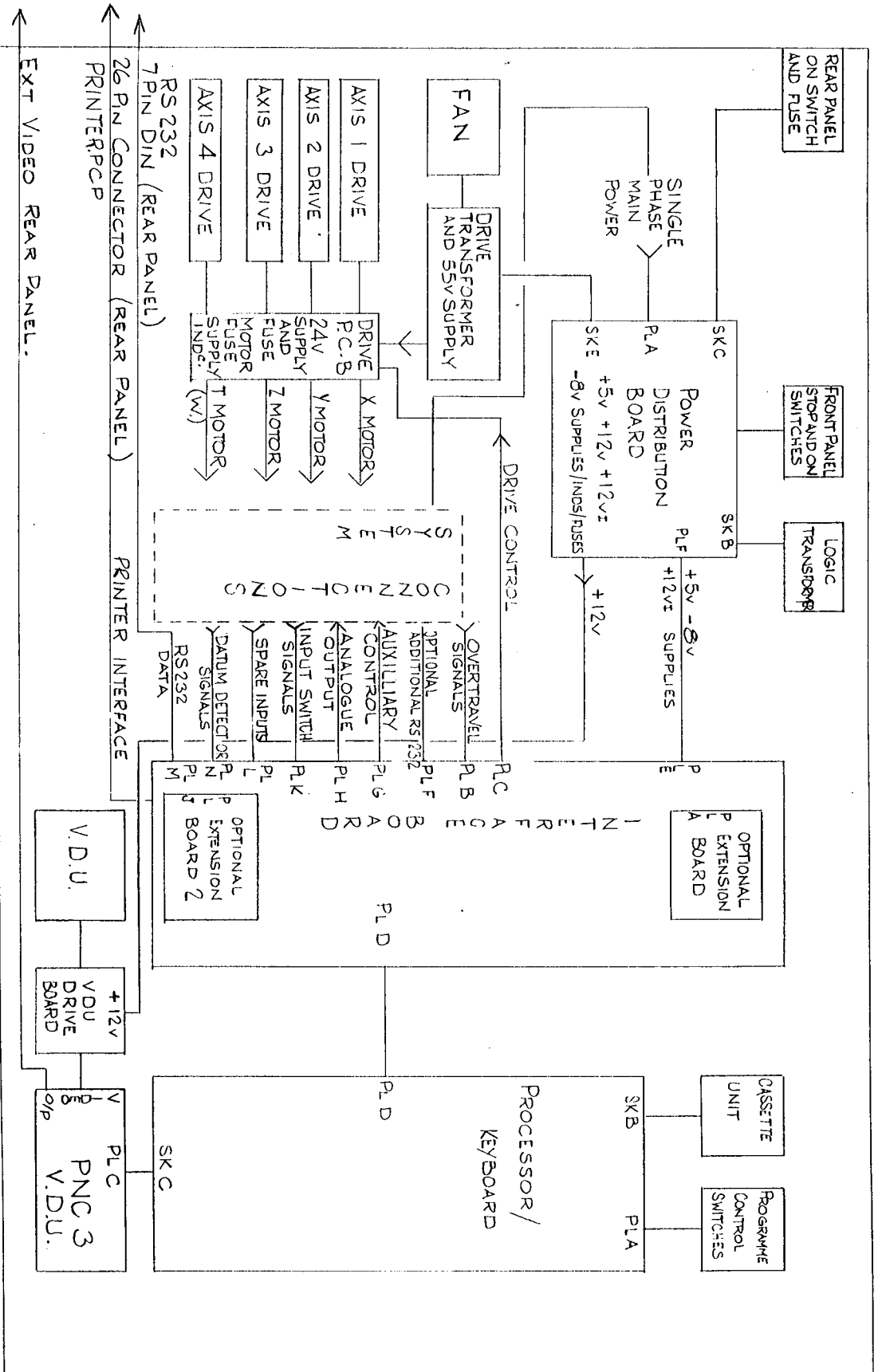

PNC3 POWER DISTRIBUTION BOARD.

LIVE TO MACHINE
4 5 P.L.A.*

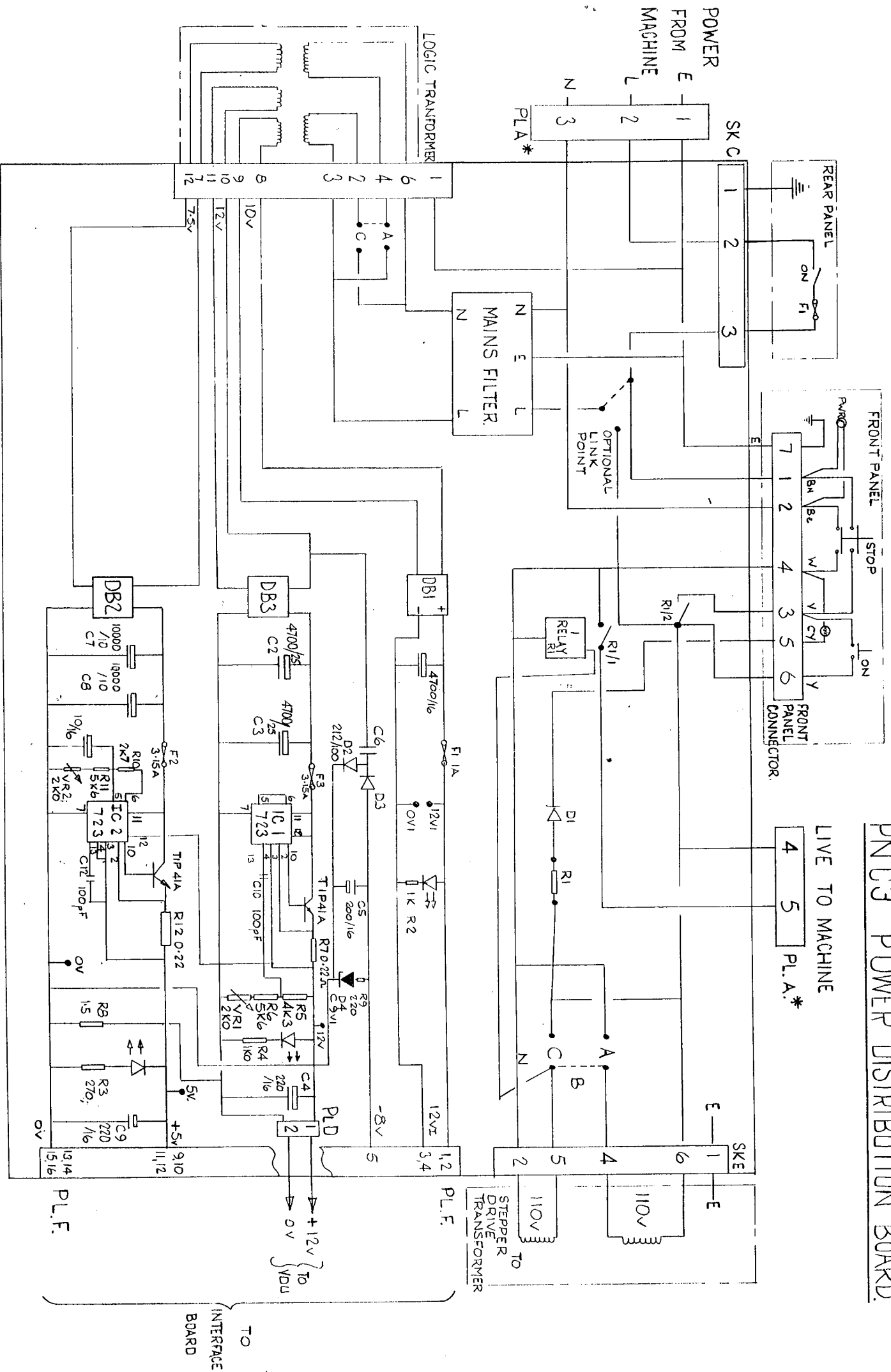

POWER FROM MACHINE

MAINS FILTER.

STEPPER DRIVE TRANSFORMER

PL.F.

TO INTERFACE BOARD

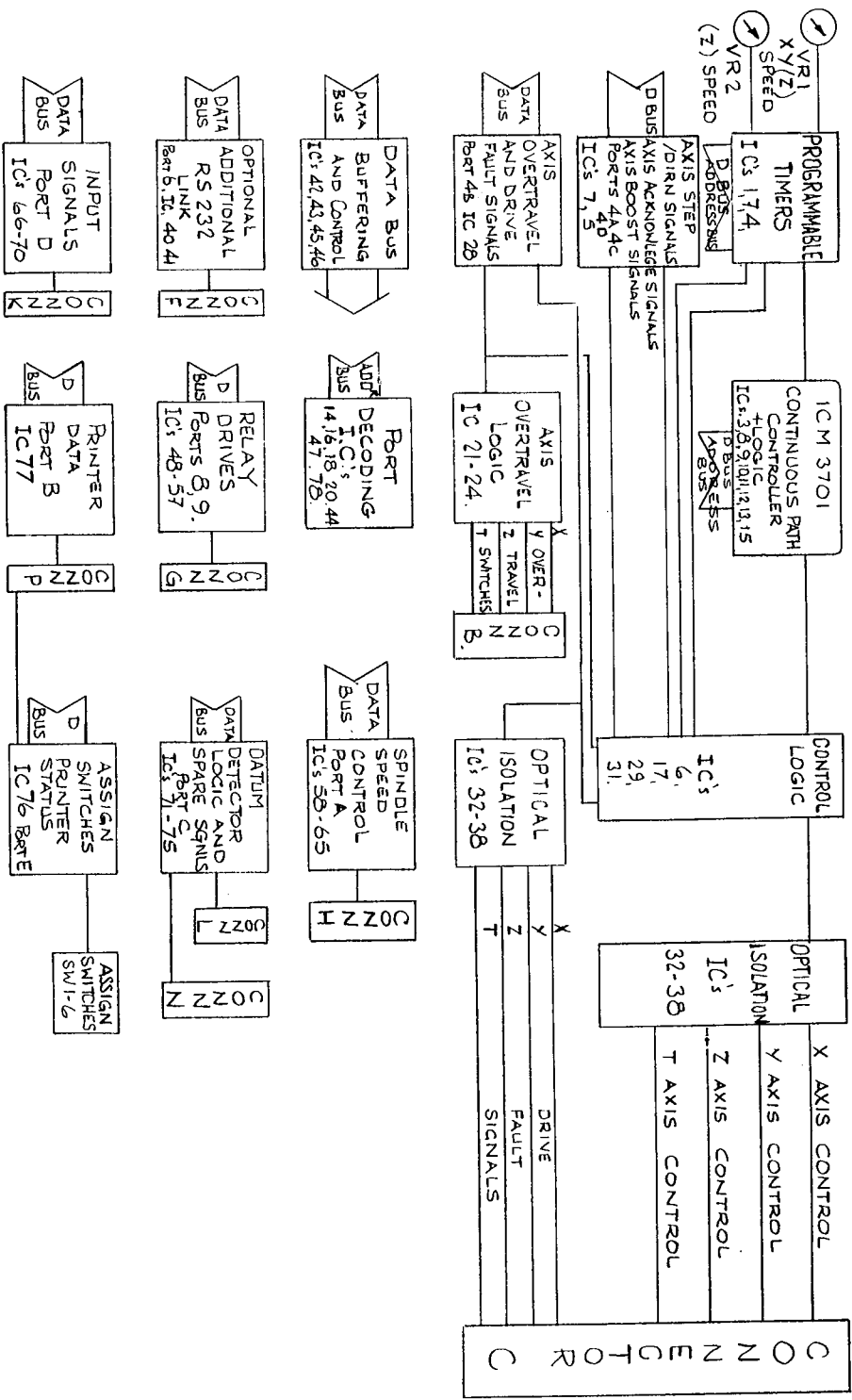

PNC 3 INTERFACE BOARD

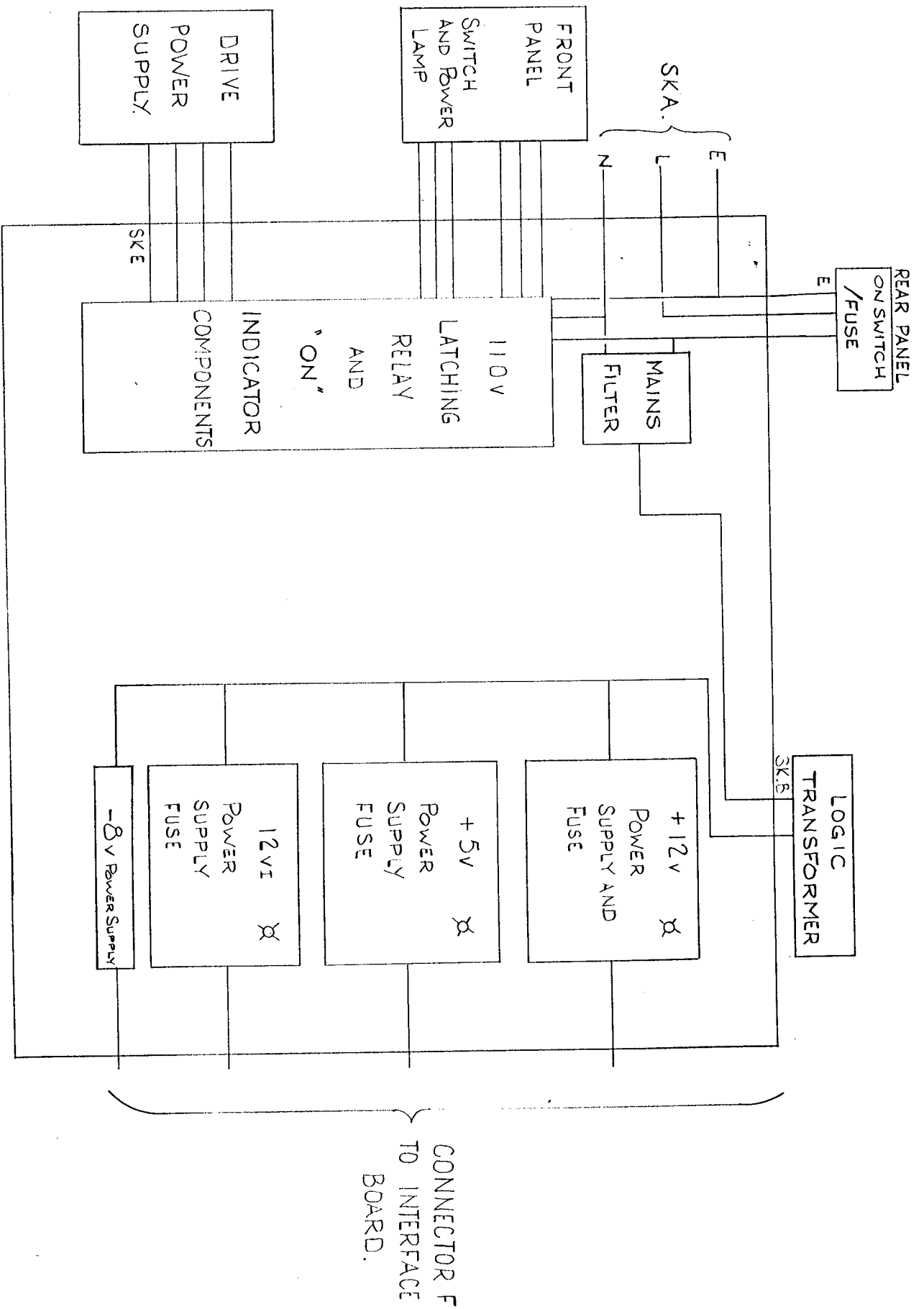

BLOCK DIAGRAM OF POWER DISTRIBUTION BOARD.

PNC PROCESSOR BOARD BLOCK DIAGRAM

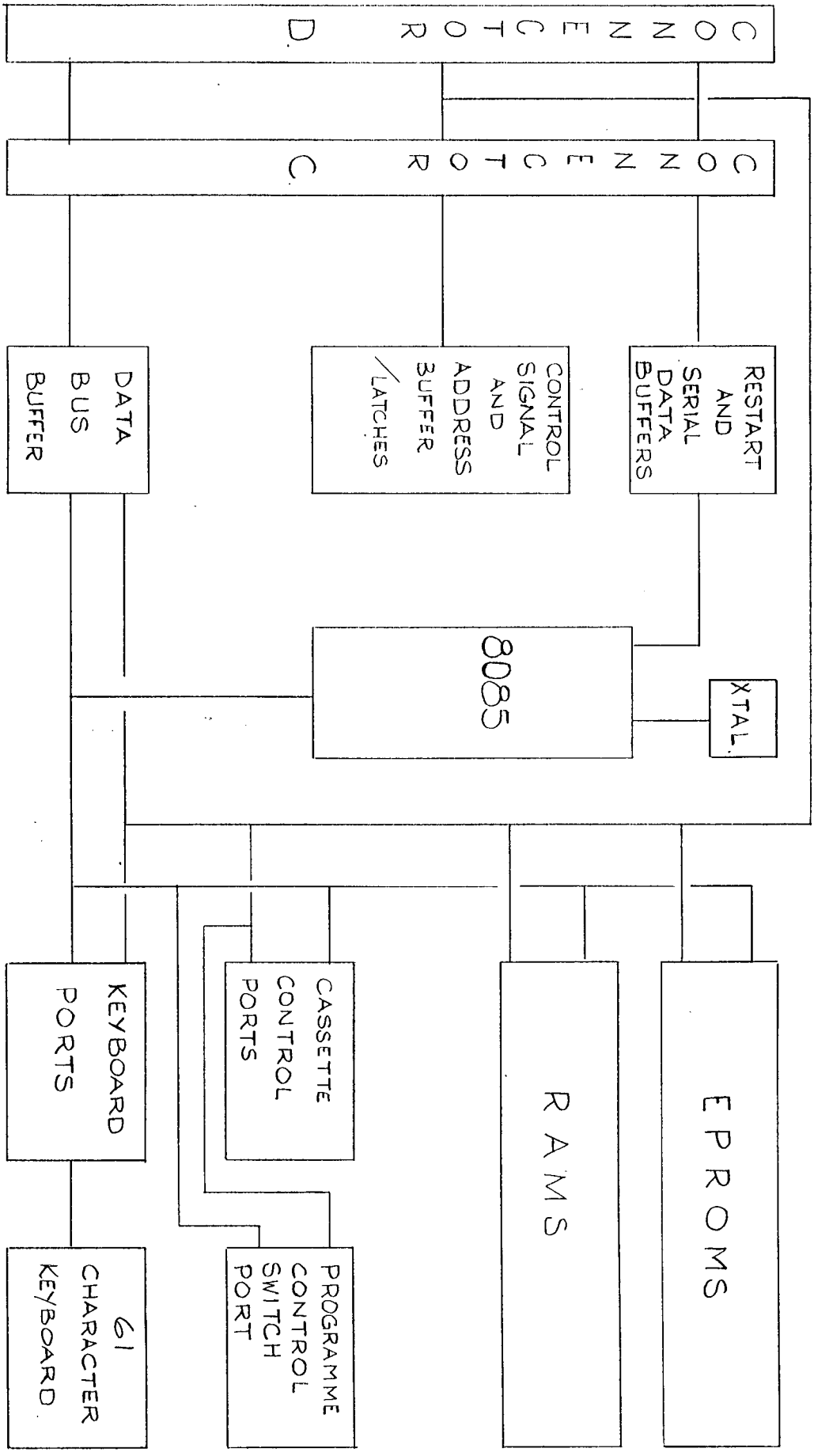

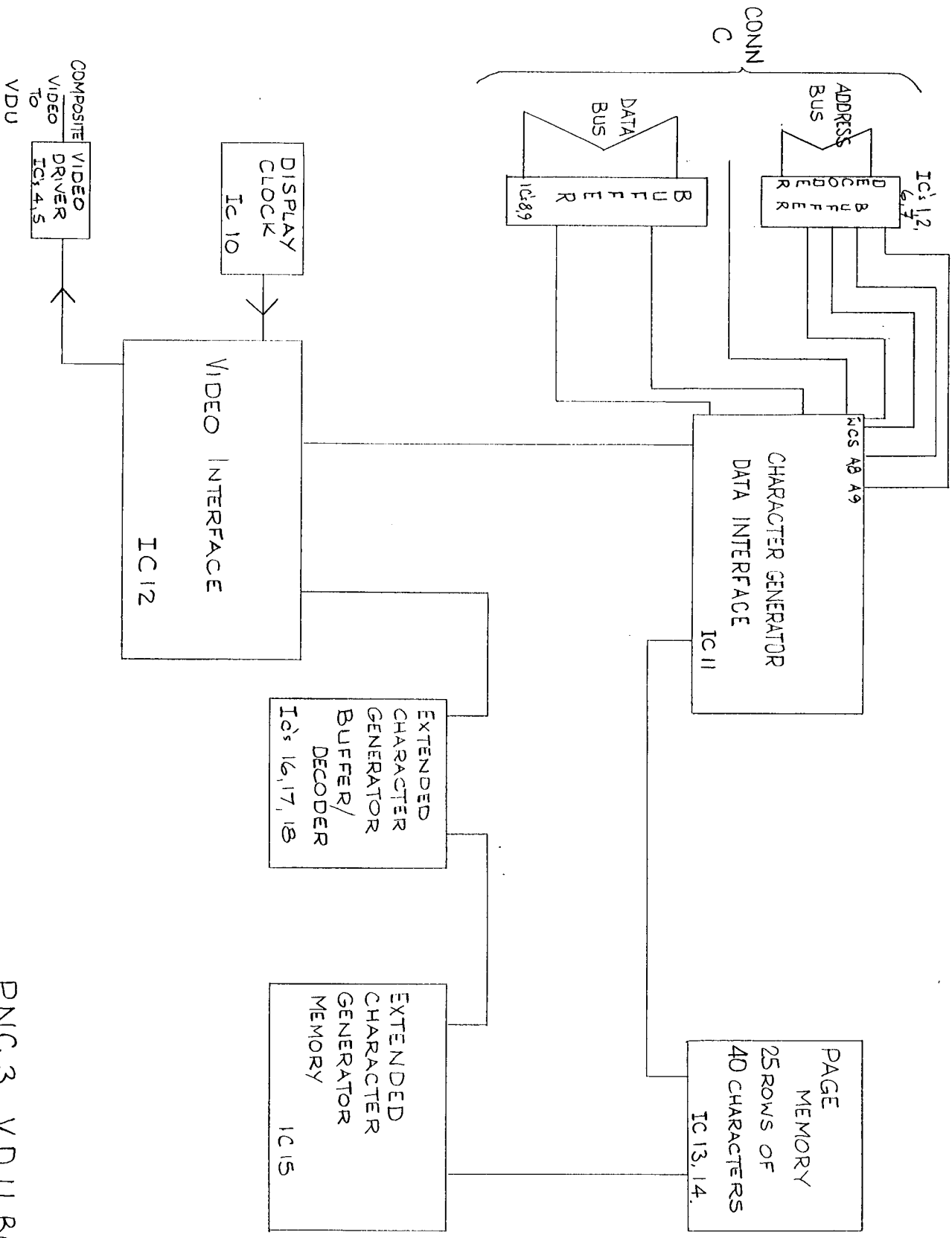

PNC 3 VDU BOARD BLOCK DIAGRAM.

North East Electronics Ltd.

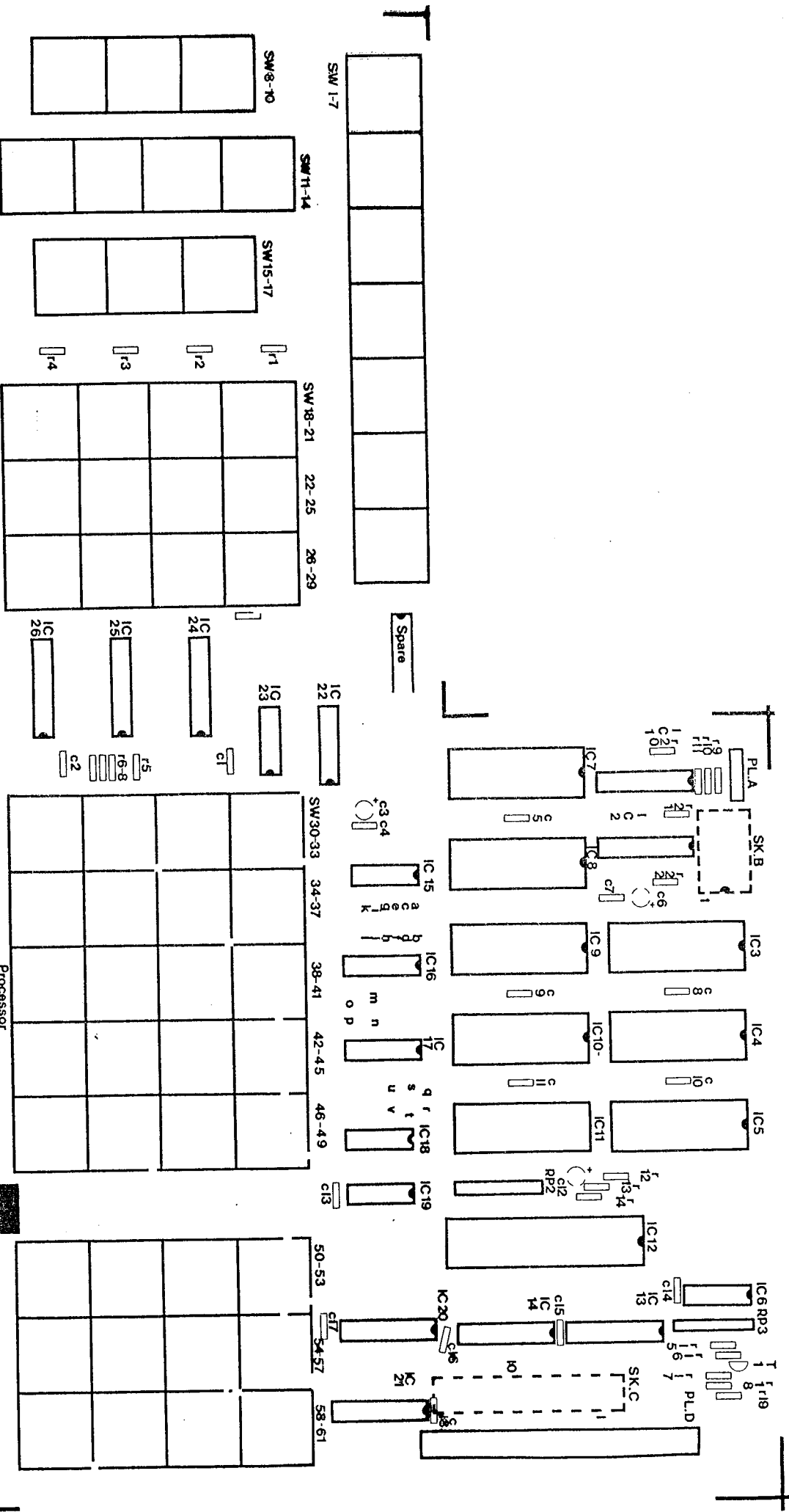

Processor
Keyboard Issue 2

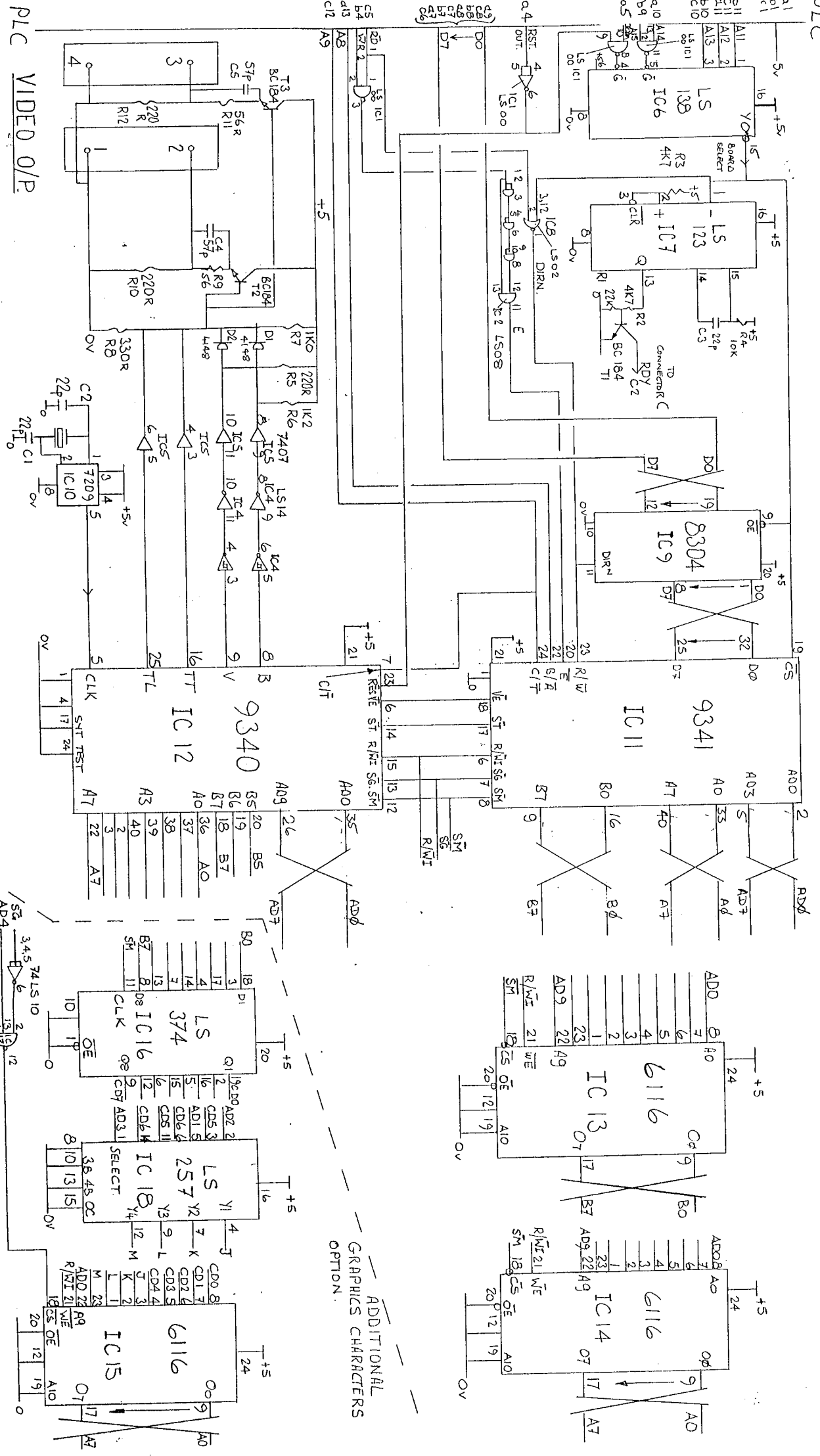

PLC VIDEO O/P

ADDITIONAL GRAPHICS CHARACTERS OPTION.

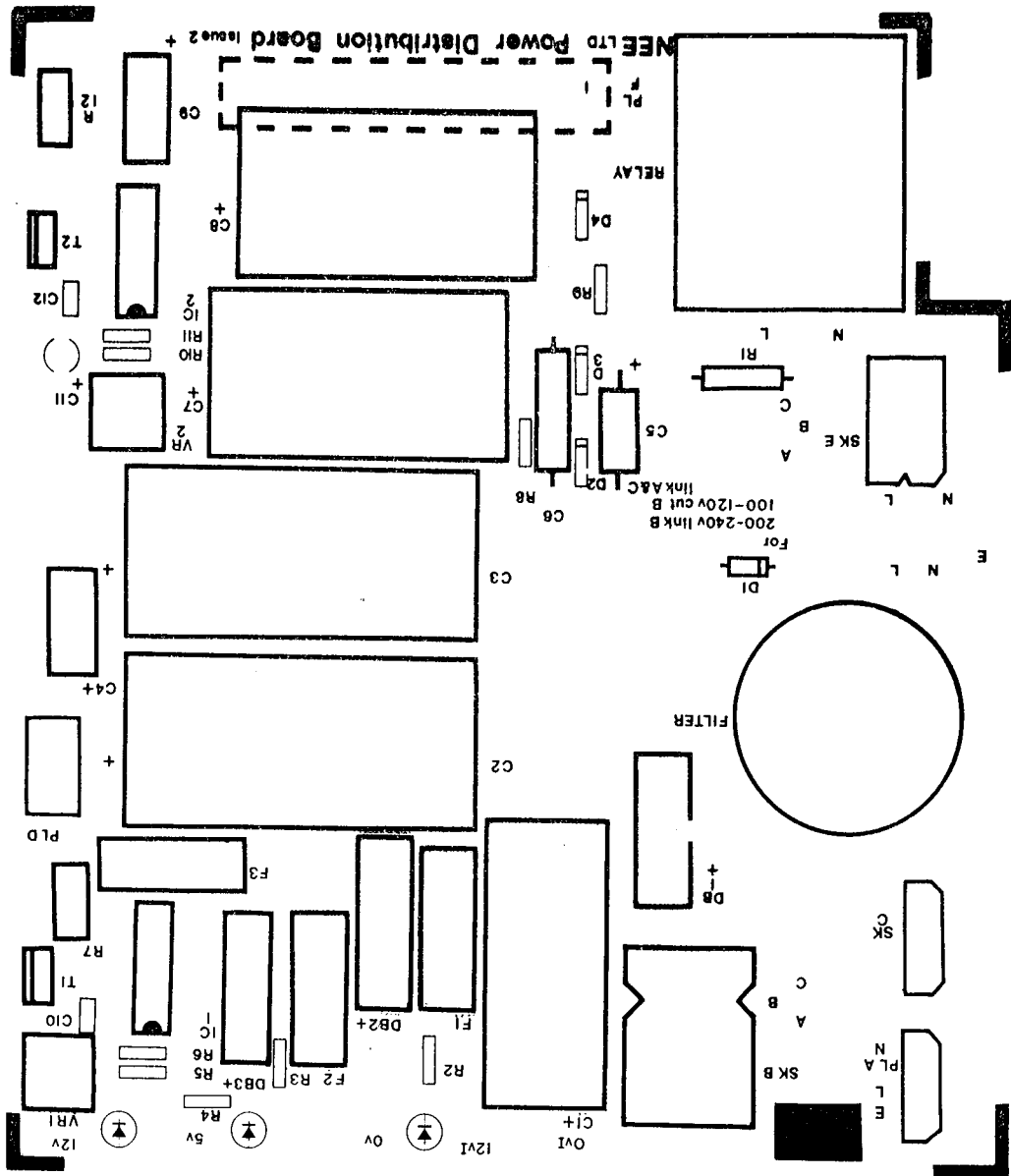

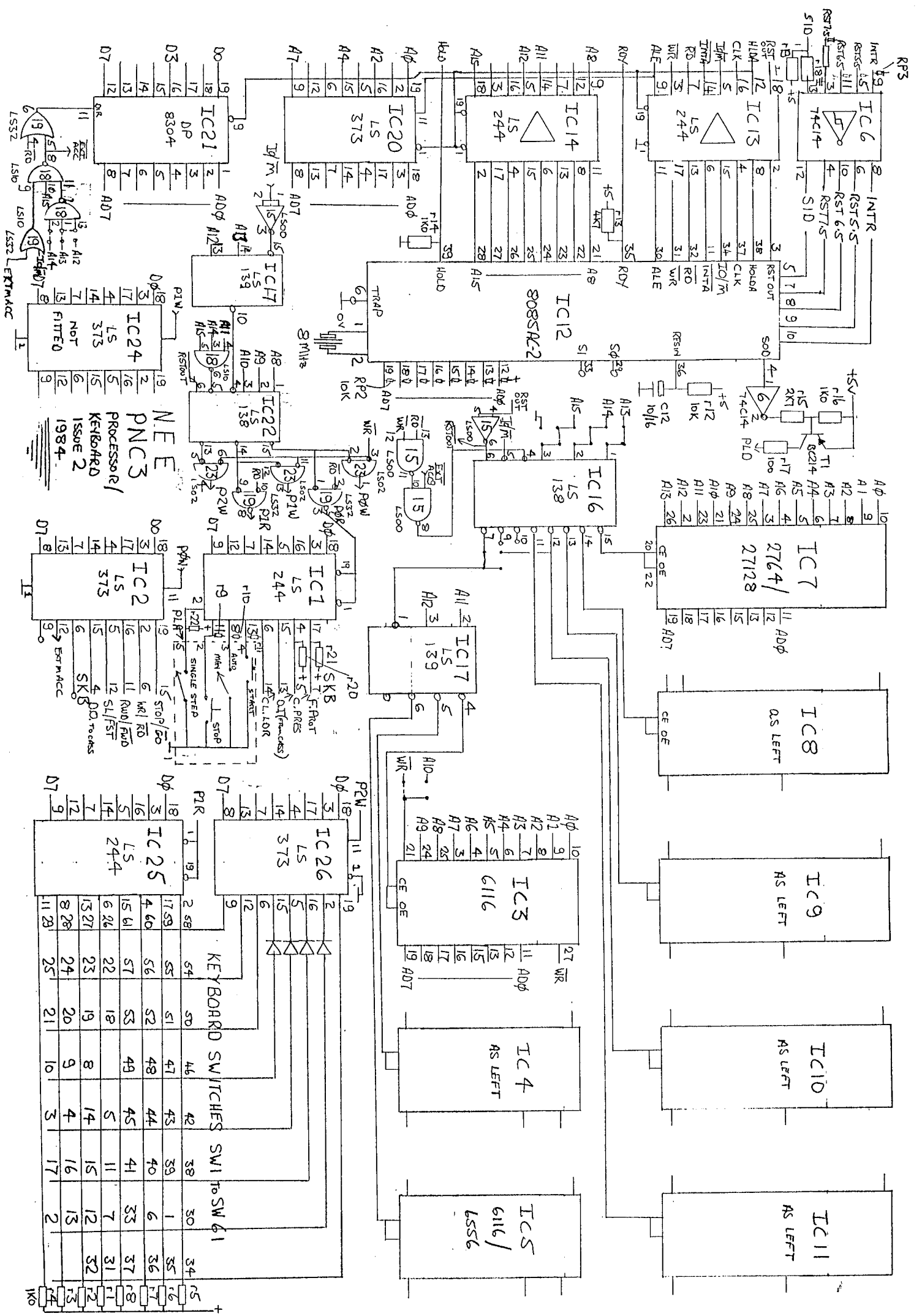

BLOCK DIAGRAM EASIMILL 3

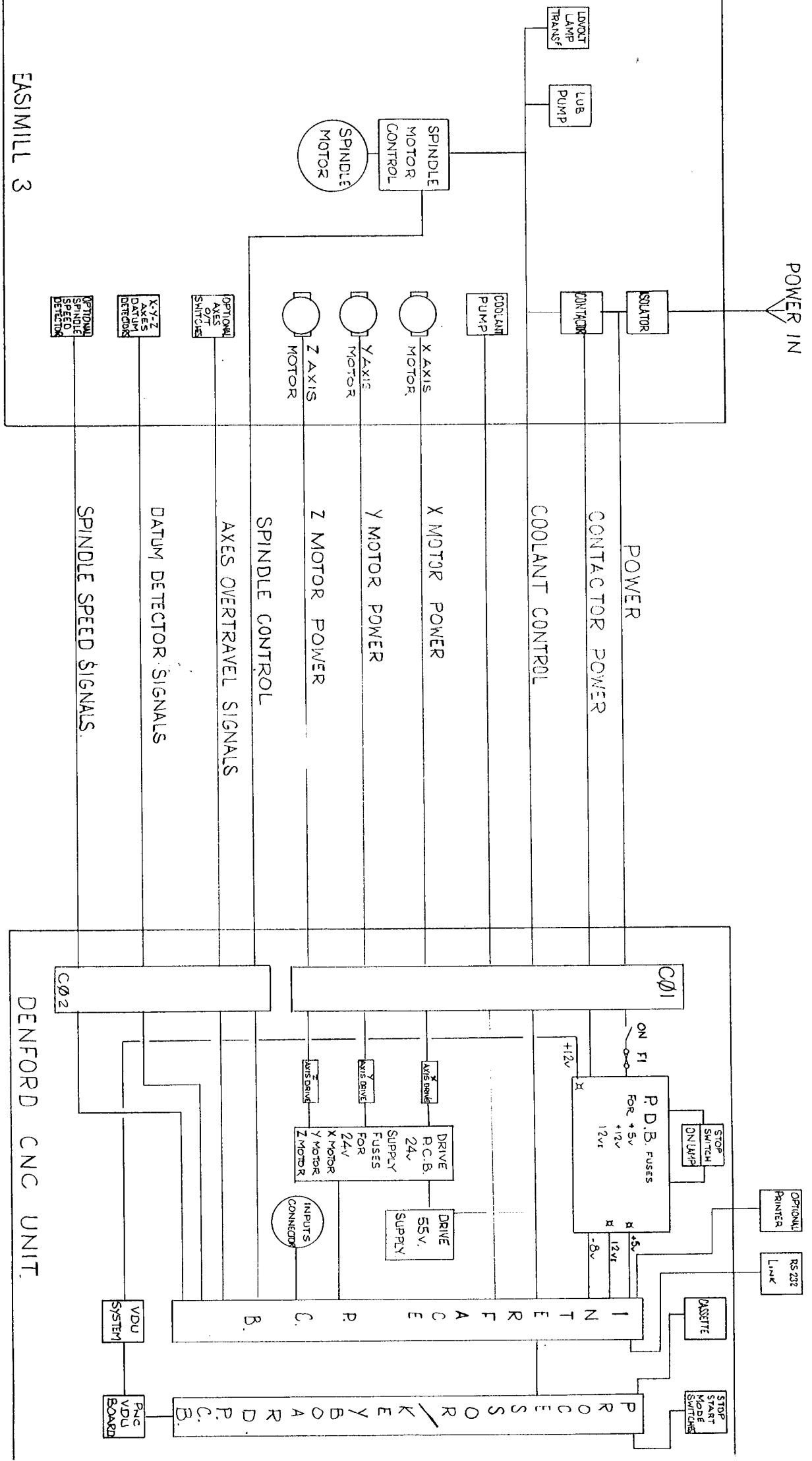

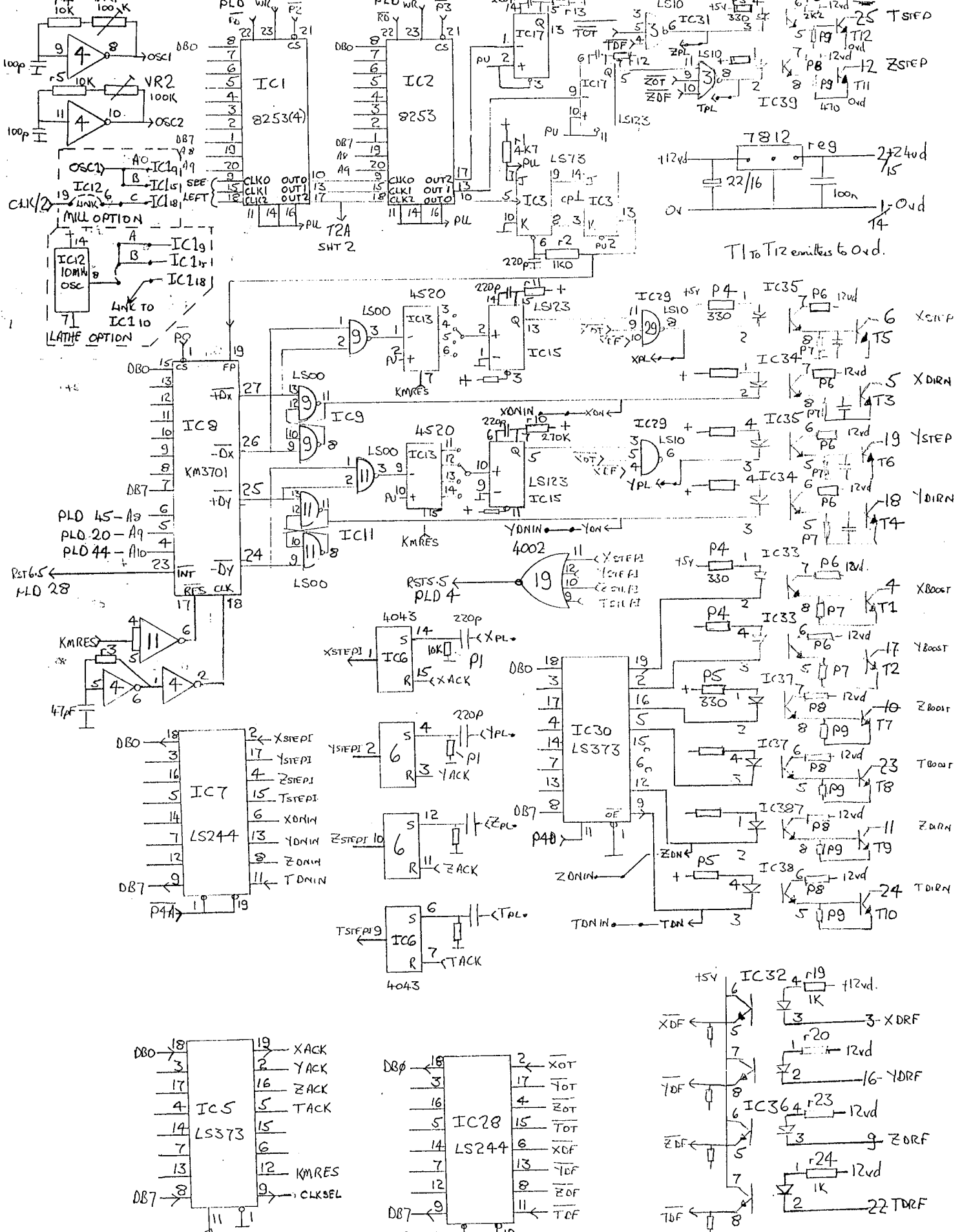

PNC 3 INTERFACE 1 OF 3

JAN 84 ISS 2

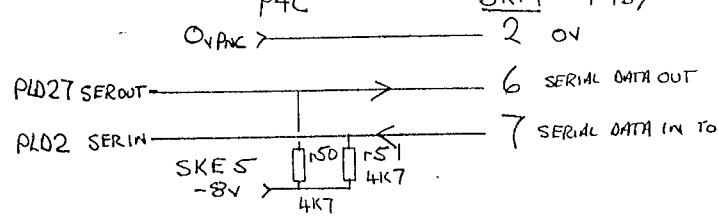

PLC ↑

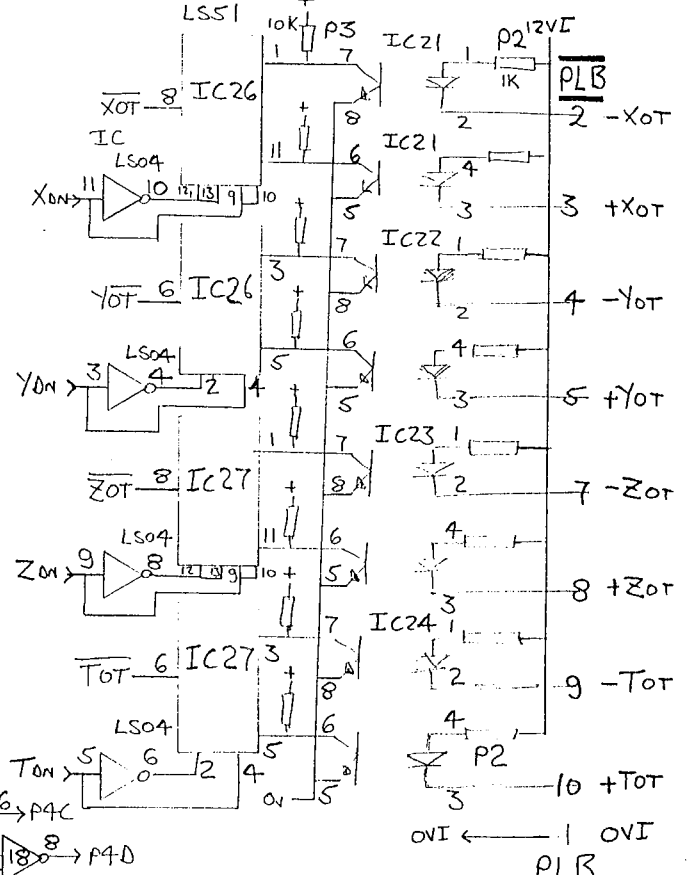
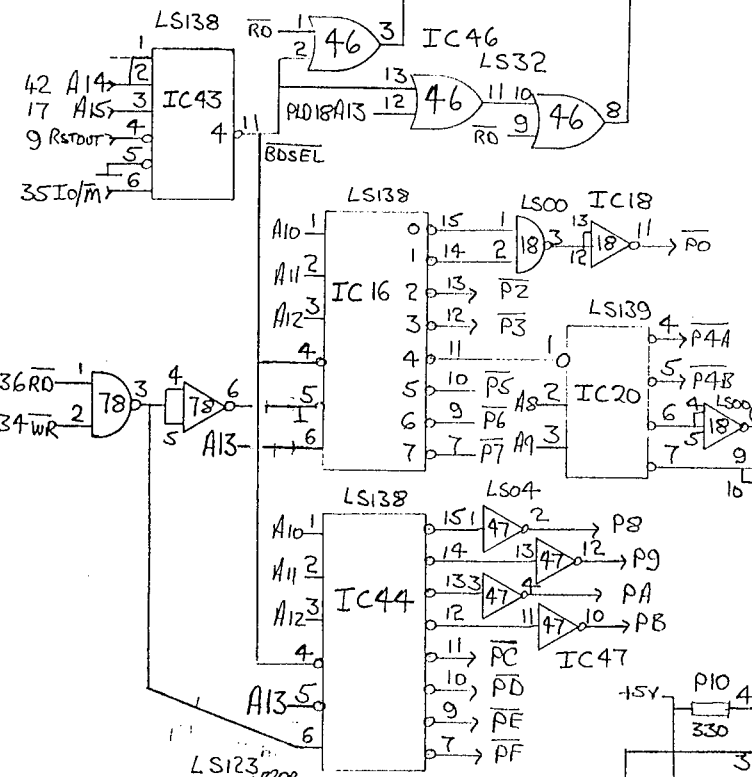
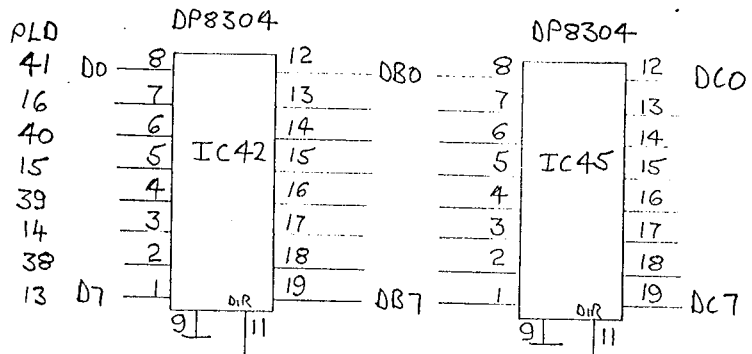

PNC 3 INTERFACE 2 of 3
JAN 84 ISS 2

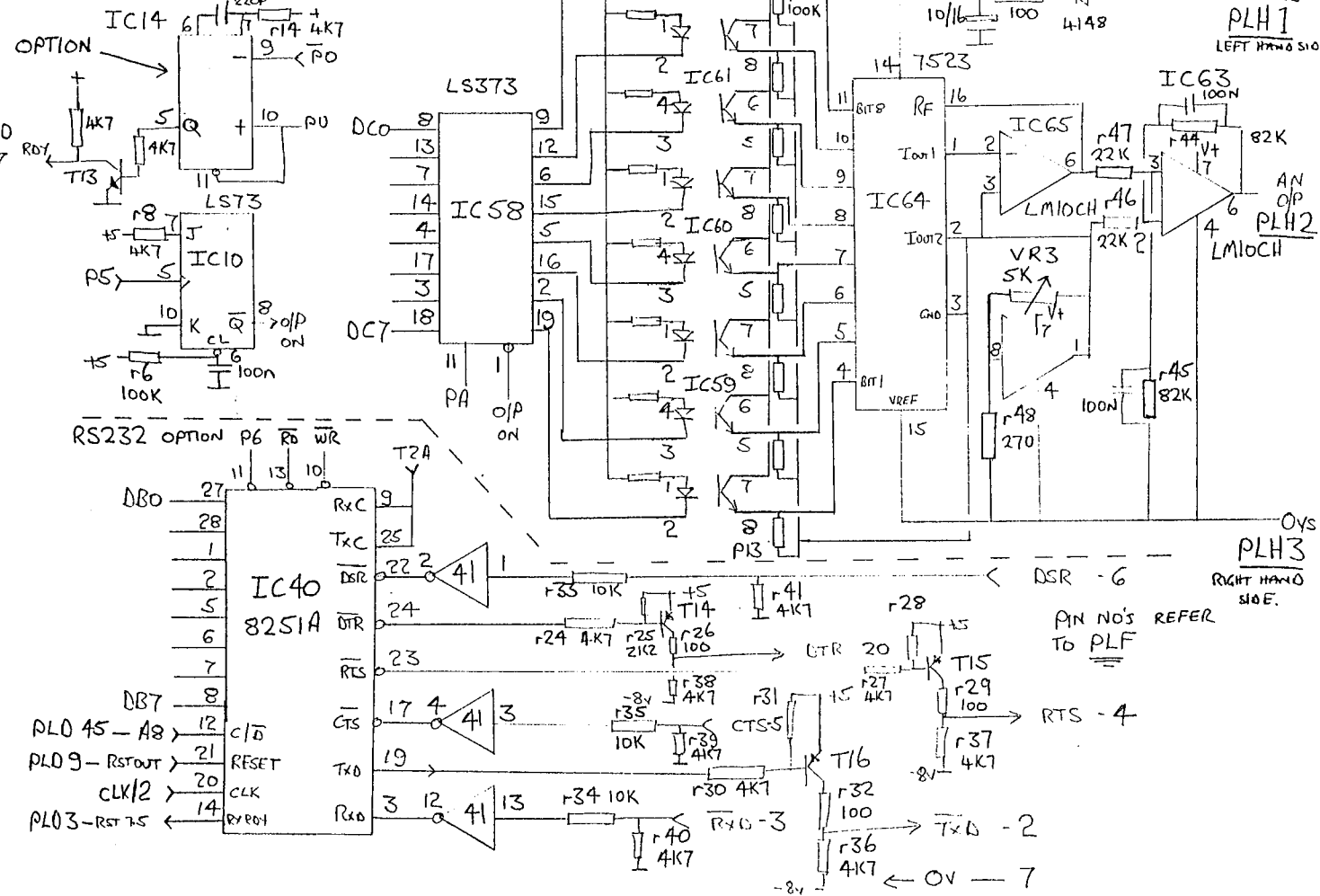

PLG PNC3 INITIATOR 3of3

JAN 84 1522

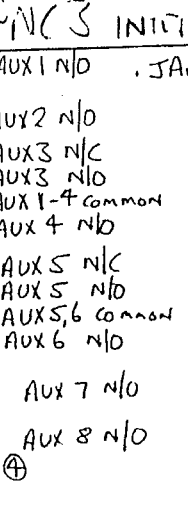
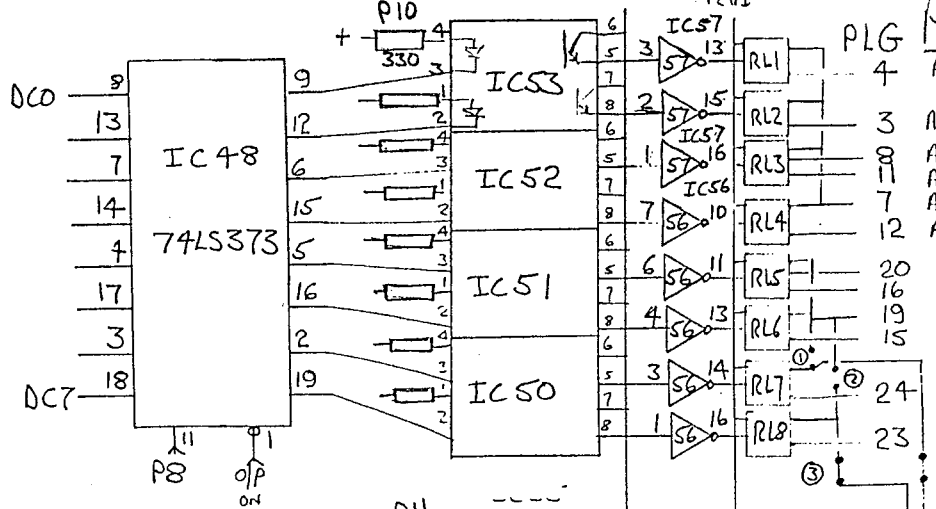

Note LINKS ① & ②
 FITTED FOR 16 AUXS
 SYSTEMS, LINKS ③ & ④
 CUT.
 LINKS ③ & ④
 FITTED FOR 8 AUXS
 SYSTEMS, LINKS
 1 & 2 CUT.

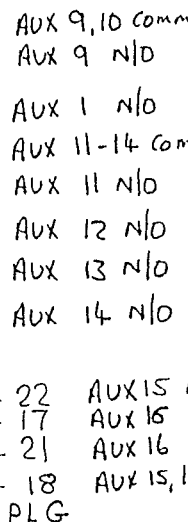
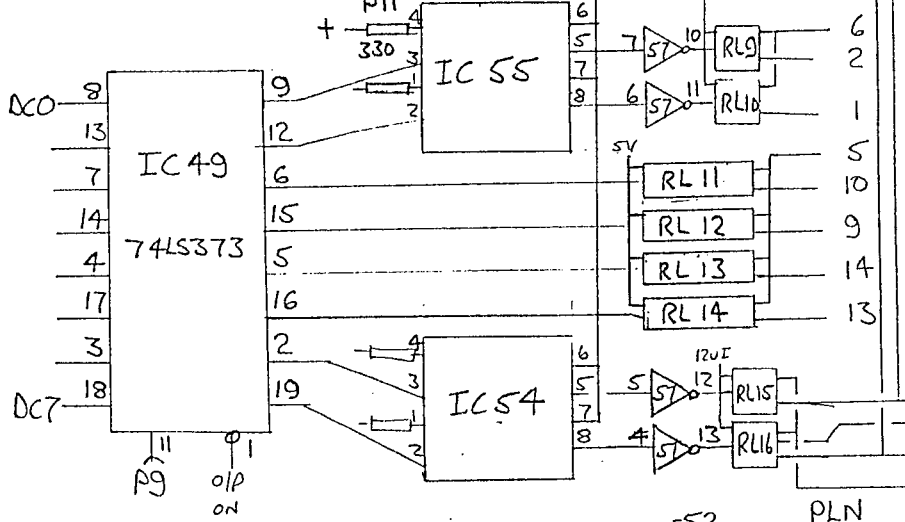

AUX 15 N/O
 AUX 16 N/C
 AUX 16 N/O
 AUX 15, 16 Common.

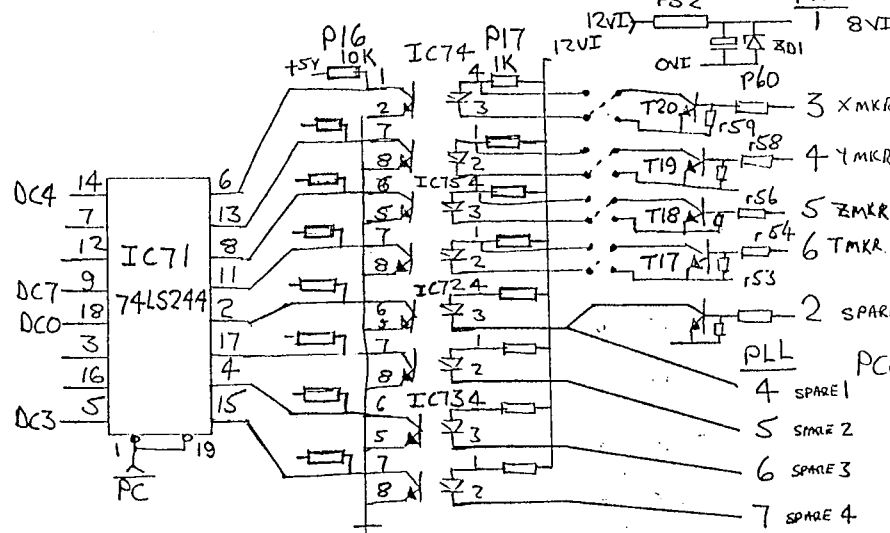

	MILL	LATHE
r52	220 1/2W	560 1/4W
r53,55	1K 1/4W	220
r54,56	2K2	560
r57,59	220	220
r58,60	560	560

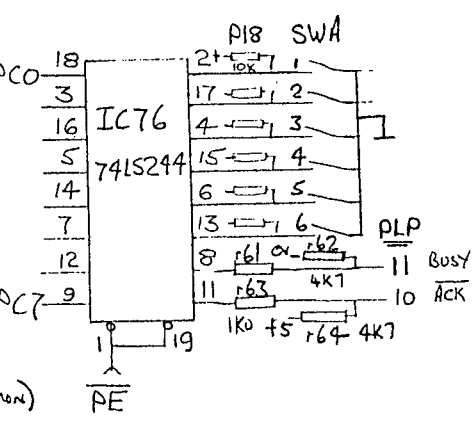
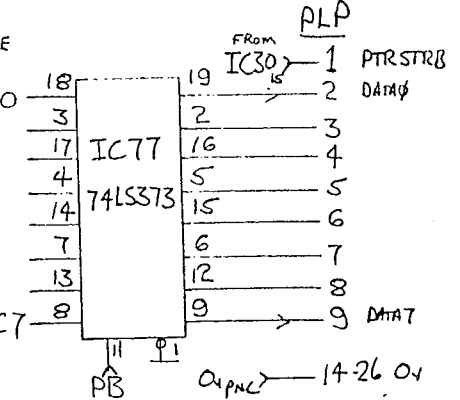
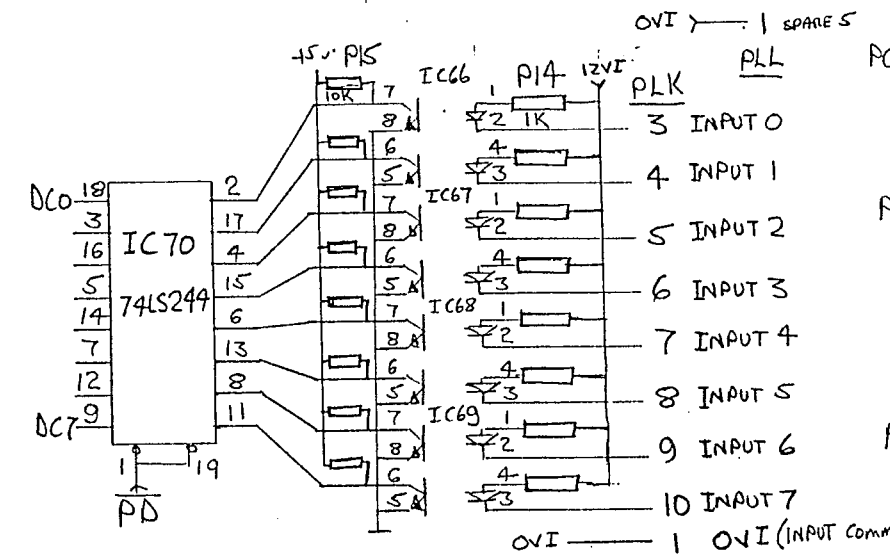

PLP
 FROM IC30
 1 PTRSTRB
 2 DATA0
 3
 4
 5
 6
 7
 8
 9 DATA7
 OI PNC 14-26 OV
 P18 SWA
 IC76 (74LS244)
 11 Busy
 10 ACK
 1K0 15 164 4K7

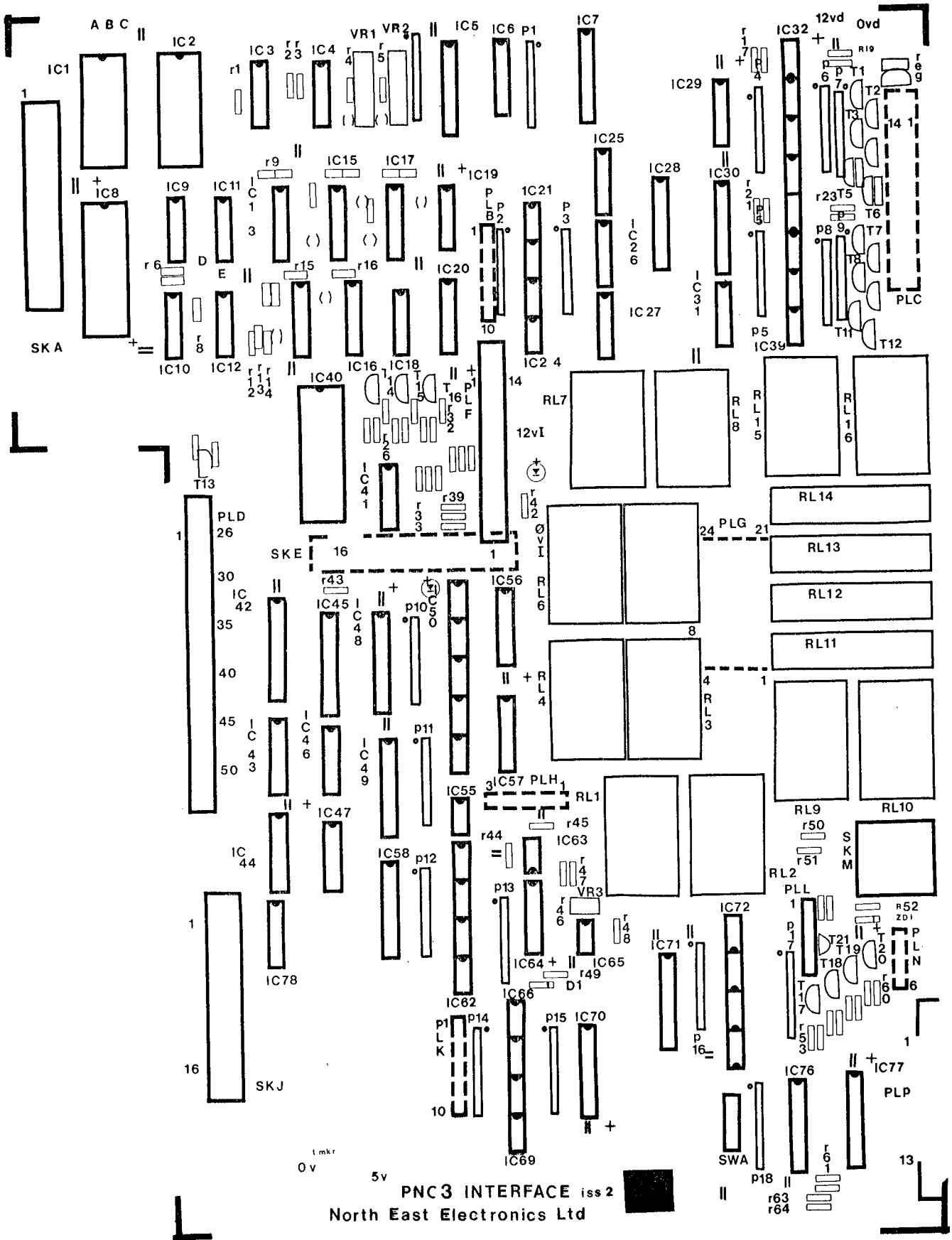

PNC3 INTERFACE iss 2
 North East Electronics Ltd

PNC 3 External Connections Layout

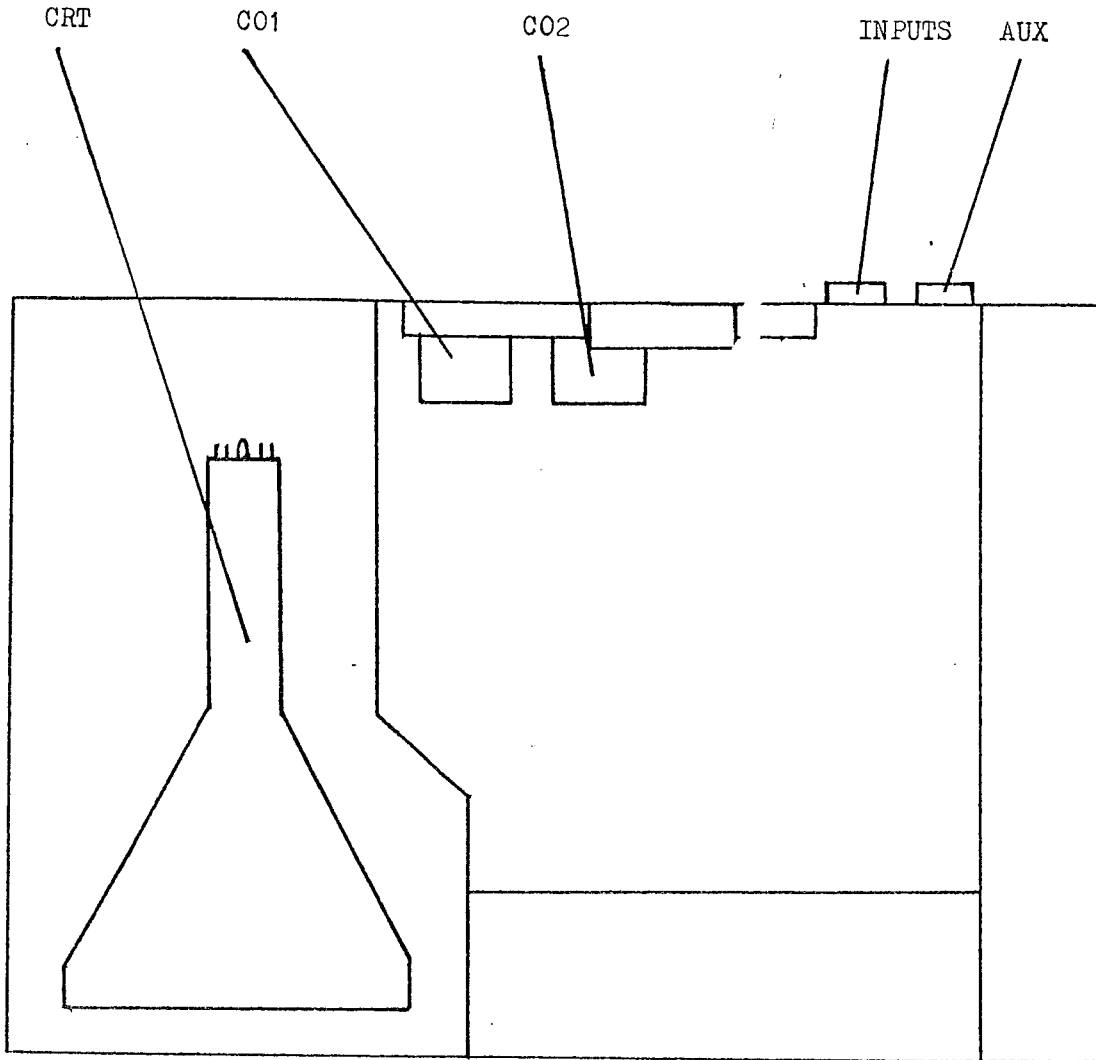

PNC3-IB-8

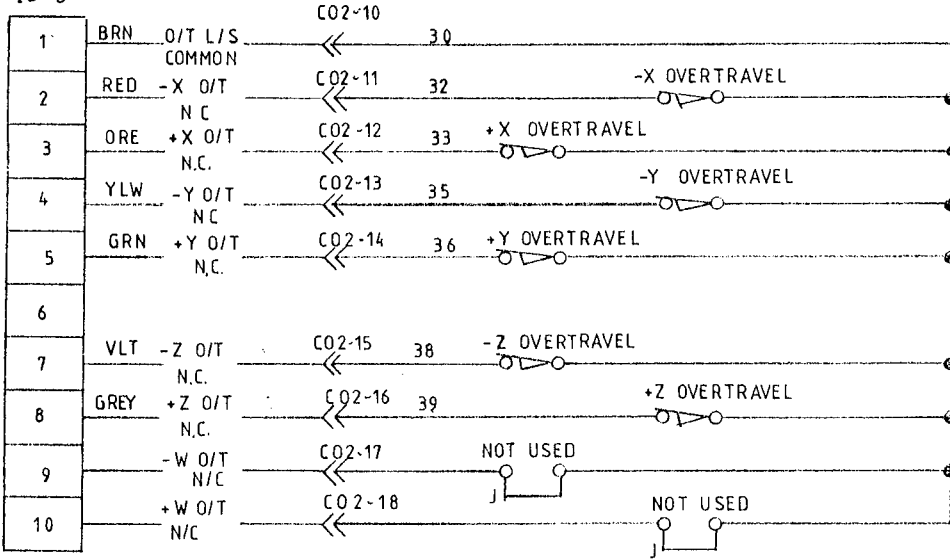

PNC3-IB-N

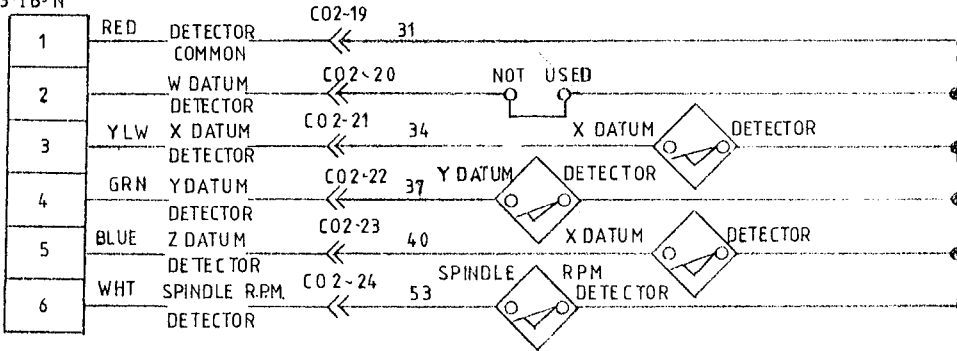

PNC3 DRIVE BOARD

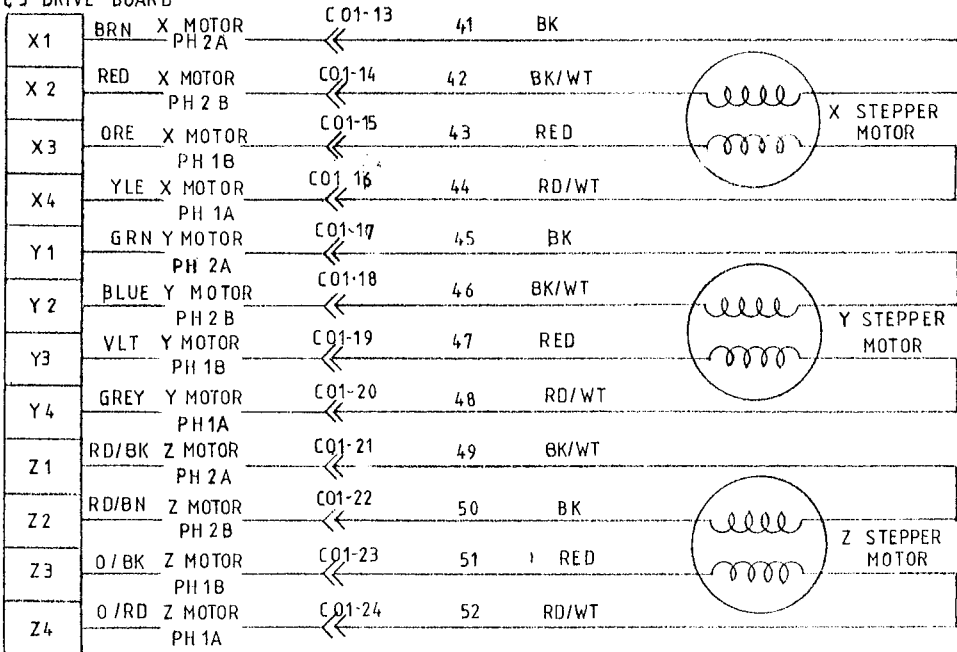

EASIMILL 3 (V S)
WIRING DIAGRAM SCHEMATIC
NO 2

SHEET No.

OF

CONT. ON

SHEET No.

COMBIVERT

N	18	FLC	27
L	17	FLB	73
T1	2	FLA	
		LOW	
R22		FRQ	
R24	1	OV	55
		REF	56
		CRF	57
		COM	71
		R	58
		F	80
		ST	59
U	19		
V	20		
W	21		

TB3	1
	2
	17
	18
	19
	20
	21
	22
	23
	24
	27
	59
	71
	72
	73

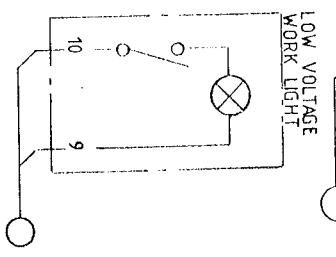
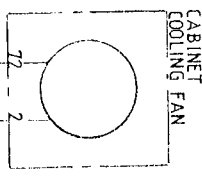
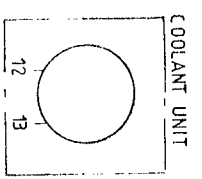
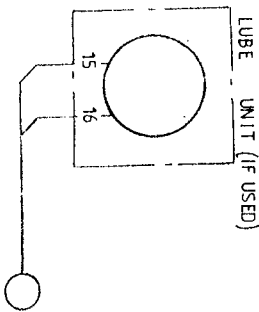
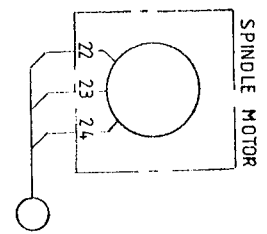
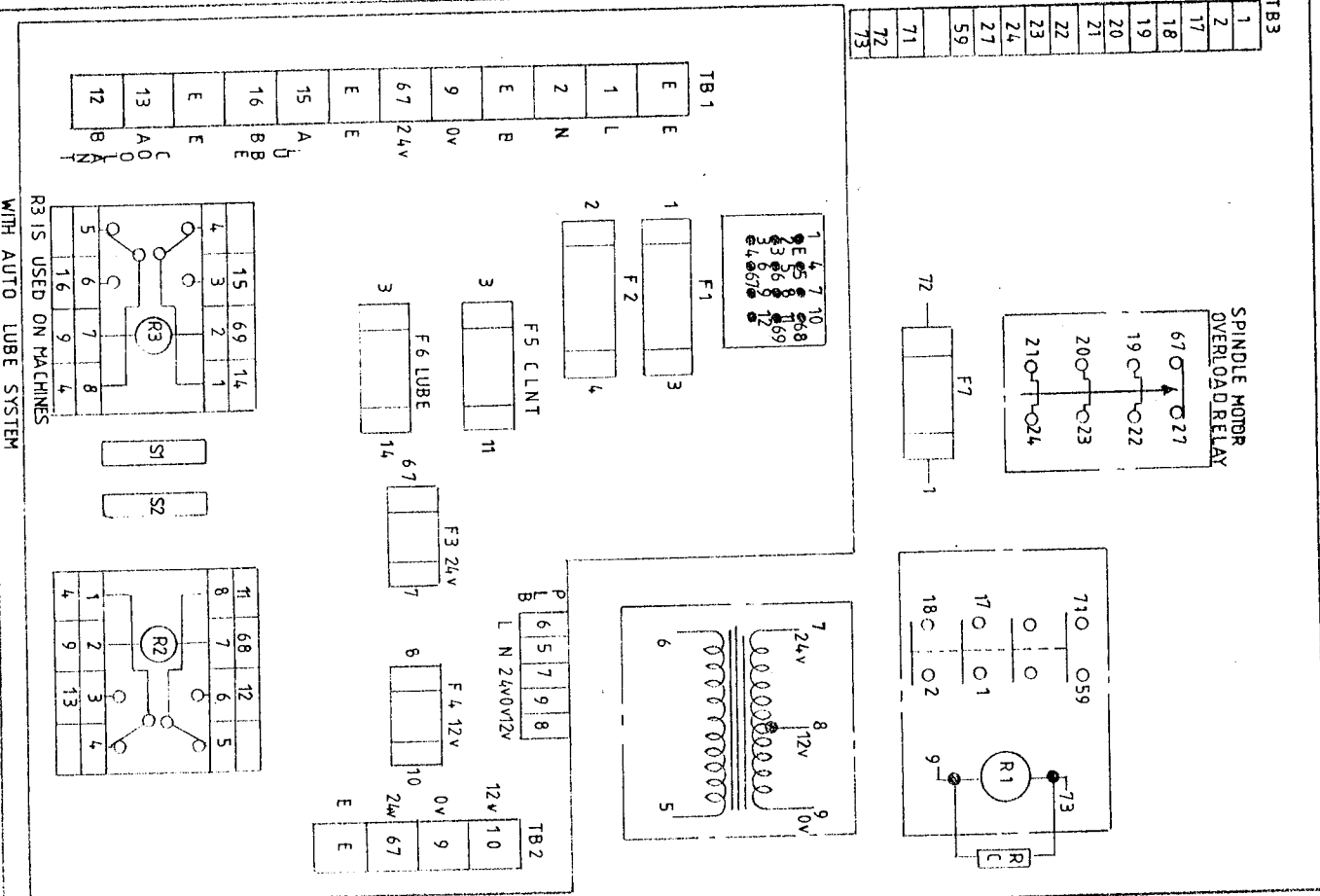

EASMILL WIRING DIAGRAM
MAGNETIC PANEL (PH COMBIVERT)
TYPE 53

SHEET No. _____
OF _____
CONT. ON SHEET No. _____

